

Flange screw isolation accessories **4 pipes**



High quality isolation materials for an electrical isolation point

Product Information

Special isolation materials for flange screws and nuts ensure the requirements of electrical separation point and prevent contact corrosions of the flange joint. The screw isolation set contains the quantities of isolating washers, Isolating sleeves and steel washers according to the flange joint size/ standard. One screw requires: two isolating washers, two steel washers and one sleeve. The screw isolation set protects the flange joint from both flange sides against the possibility of electrical short-circuit fault through nut and screw. The screw isolation set can be delivered for all common flange standards, sizes and pressure rates.

Usage

- New installation areas
- In connection with flange isolation gaskets
- Also usable for replacement of existing flange joints to an isolating flange connection

Isolation Screw

Screws are factory covered with isolating epoxy resin/glass fabric material. One isolating screw contains two isolating washers, two steel washers and one screw- nut. The Isolation screws steel quality and grade are made according to customer specification. (Standard screw grade is 8.8 galvanized)

Isolating Washer

- G10 (standard)
- G11 (special)

Isolating Sleeve

- Mylar (standard)
- Nomex (special)

Steel Washer

- Steel ST37, galvanized DIN 126 (standard)
- Stainless steel V4A (special)

Standard Isolating Kit =

Isolating Washer: G10
Isolating Sleeve: Mylar
Steel Washer: steel galvanized

Special (selection of combination) Isolating Kit =

Isolating Washer: G10 or G11
Isolating Sleeve: Mylar or Nomex
Steel Washer: steel galvanized or stainless steel

Technical Data

Please find the dimension and pressure rates in our price list or ask us.

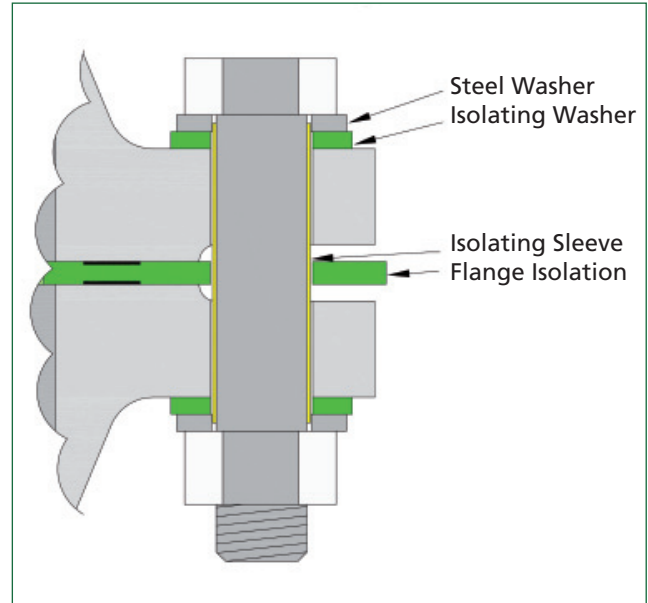

| Characteristics: | G10 | G11 | Mylar | Nomex | Isolating Screw |
|-----------------------|-----------------------------|-----------------------------|---------------------------|-----------------------------|-----------------------------|
| Material | Epoxy resin glass fabric | Epoxy resin glass fabric | Spiral wound polyester | Armid spiral wound paper | Epoxy resin glass fabric |
| Operating temperature | -60°C bis +130°C | -60°C bis +180°C | -60°C bis +150°C | -196 °C bis +200 °C | 200°C |
| Water absorbtion | <0,1 % | <0,1 % | <0,8 % | < 0,1% | <20 mg |
| Dielectrical strength | 20.000 V/mm | 60.000 V/mm | 160.000 V/mm | 22.500 V/mm | 300.000 V/mm |

Installation guide

Follow assembly instruction for a proper operation of the flange isolation.

1. The sealing surface of the flange has to be clean, free of grooves and edges (Flange surface according to DIN/ASME standard)
2. Insert the gasket carefully between the flange sealing surfaces
3. Lubricate screws
4. Insert screws incl. isolation washers and sleeve through the bolt hole and hand tighten them:
The steel washer will be placed on the screw head and nut; the isolation washer will be placed directly on the flange.
The bore holes of the flanges and isolation gasket have to be aligned with each other.

Calculation of isolation sleeve length:

$2 \times \text{flange thickness incl. raised face} + \text{thickness of flange isolation gasket} + 2 \times \text{thickness of isolation washer} = \text{sleeve length}$

5. Tighten screws evenly (in three steps 30% + 40% + 30%) with a torque wrench acc. to the tightening torque table spec.

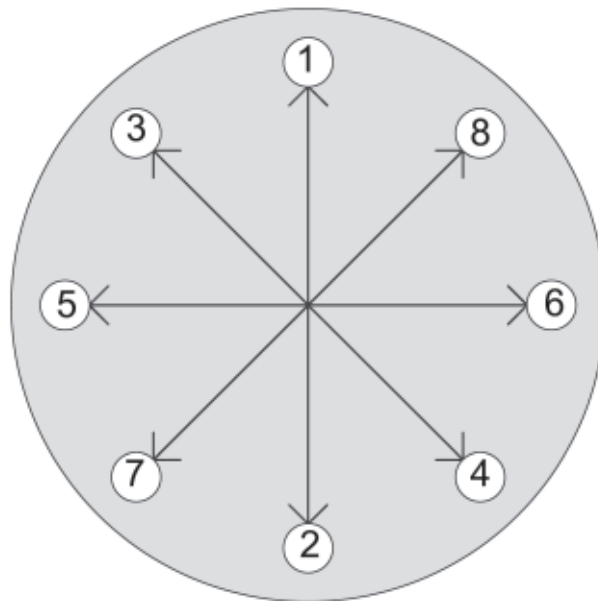

Tightening torque for flange screws

| Screw-size Metric | Screwgrade | | | | | | Screw-size Inch | Screwgrade | |
|-------------------|---------------------|--------|--------|--------|---------|---------------------------------------|-----------------|------------|----------|
| | 5.6 Ck 35 | 8.8 | 10.9 | 12.9 | A2 - 70 | 42 CrMo 4 A 320 L7M 40 CrMoV 47 | | | A 193 B7 |
| | in Newtonmeter (Nm) | | | | | | | | in Nm |
| M10 | 21 | 50 | 70 | 85 | 34 | 30 | | | |
| M12 | 37 | 85 | 120 | 145 | 59 | 52 | 1/2 - 13 UNC | 80 | |
| M16 | 90 | 210 | 300 | 350 | 145 | 128 | 5/8 - 11 UNC | 160 | |
| M20 | 180 | 410 | 570 | 690 | 280 | 264 | 3/4 - 10 UNC | 320 | |
| M22 | 240 | 550 | 780 | 940 | 380 | 360 | 7/8 - 9 UNC | 480 | |
| M24 | 310 | 700 | 1.000 | 1.200 | 480 | 456 | 1 - 8 UNC | 750 | |
| M27 | 450 | 1.050 | 1.480 | 1.775 | - | 672 | 1-1/8 - 7 UNC | 1.050 | |
| M30 | 610 | 1.400 | 2.000 | 2.400 | - | 912 | 1-1/4 - 7 UNC | 1.450 | |
| M33 | 830 | 1.900 | 2.700 | 3.250 | - | 1.240 | 1-3/8 - 6 UNC | 1.900 | |
| M36 | 1.060 | 2.500 | 3.450 | 4.200 | - | 1.600 | 1-1/2 - 6 UNC | 2.500 | |
| M39 | 1.380 | 3.200 | 4.500 | 5.400 | - | 2.080 | 1-3/4 - 8 UNC | 4.600 | |
| M42 | 1.700 | 4.000 | 5.600 | 6.700 | - | 2.560 | 2 - 8 UNC | 8.400 | |
| M45 | 2.120 | 5.000 | 7.000 | 8.400 | - | 3.200 | 2-1/4 - 8 UNC | 9.800 | |
| M48 | 2.570 | 6.000 | 8.450 | 10.150 | | 3.840 | | | |
| M52 | 3.310 | 7.750 | 10.800 | 13.000 | | 4.960 | | | |
| M56 | 4.120 | 9.600 | 13.500 | 16.200 | | 6.200 | | | |
| M60 | 5.130 | 12.000 | 16.800 | 20.200 | | 7.680 | | | |

Note:

- The flange screws have to be greased/ lubricated generally for the installation
- For Gas systems , it is advisable to use a PTFE based grease (common greases contain hydrocarbons which could cause incorrect gas measurement readings with a gasometer)

Warning: For DIN flanges with screw grades ≥ 8.8 , we advise to use 80% of the tightening torque. 100% tightening torque could deform the flange blades.