



Lappajärvi, Finland

+358 40 566 4018

info@jake.fi

www.jake.fi

## Disconnecting the crane from the tractor with a JAKE 600, JAKE 800 or JAKE 900

1. Choose a flat and hard surface for disconnecting, preferably asphalt or concrete.

2. Open the locking bolts above the sleeves of the JAKE ca. 10 mm. Do not remove the bolts entirely! The JAKE 800 and JAKE 900 have locking bolts also under the sleeves, remove these lower bolts completely.

3. Move the crane boom sideways in the air for loosening the JAKE Crane Part from the sleeves. Press also the grapple to the ground at times. If the Crane Part does not come loose this way, turn the boom forward, drive the telescope fully out, keep the boom and the grapple in the air and tighten the releasing bolts (delivered with the JAKE) under the sleeves. Turn the boom backward, telescope fully out, lift the grapple ca. 3 metres from the ground, lower down the main boom with some speed and stop the move quickly. This forces the Crane Part to come loose.

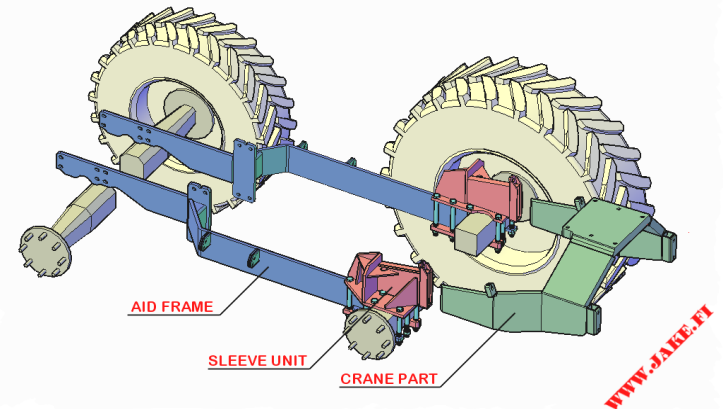

**N.B ! Only loose the upper locking bolts 10 mm, do not remove them yet ! This prevents the Crane Part from coming completely out of the sleeves accidentally !**

4. When the Crane Part is loose, take a heavy load in the grapple, for instance a heavy log, and stretch the crane boom straight backward to its full outreach. Set the grapple and its load against the ground so that the grapple can not tip over while the crane is parked without the tractor.

5. Fasten the parking legs with their paws (delivered with the JAKE) into their fastening sockets on the sides of the Crane Part, but do not tighten the legs yet. Notice that the connection between the Crane Part and the sleeves must be already loose.

6. Press the crane boom against the ground for lightening the weight on the tractor's rear wheels and tighten the parking legs. (Notice that the crane weight does not lay on the tractor when you connect the crane back to the tractor later.)

**N.B ! The parking legs do not stand backward or forward moving of the crane ! Be sure the parking legs are tight enough to carry the crane !**

7. Remove the upper locking bolts entirely and drive the tractor ca. 20-25 cm forward with extremely high caution so that the Crane Part does not come entirely out but stays ca. 5-10 cm into the sleeves.  
**N.B ! Be sure the crane does not tip over towards the tractor !**

8. Adjust the crane position with pulling the telescopic boom in so that the Crane Part shafts' lower surfaces get loose of the sleeves' bottoms. That way the crane weight is away from the tractor's rear wheels and reconnecting the crane is easier.

9. Drive the tractor forward as much as the hydraulic hoses between the crane and the tractor allow and disconnect the hoses, valves and other necessary crane parts from the tractor.

**ALWAYS BE SURE THE TRACTOR STAYS STILL AND THAT THE CRANE CAN NOT TIP OVER WHILE WORKING BETWEEN THE TRACTOR AND THE CRANE !**

**NEVER PARK THE CRANE ON A FROZEN, SNOWY OR SLOPING SURFACE !**