

TYRE TECHNICAL FORM
FICHE TECHNIQUE DU PNEUMATIQUE



PNEUMATIQUE / TYRE

Manufacturier	<i>Tyre Manufacturer</i>	VEGA S.p.A.
Marque	<i>Make</i>	VEGA
Modèle	<i>Model</i>	SLICK MINI 10x4.00-5
Nombre de pages	<i>Number of pages</i>	3

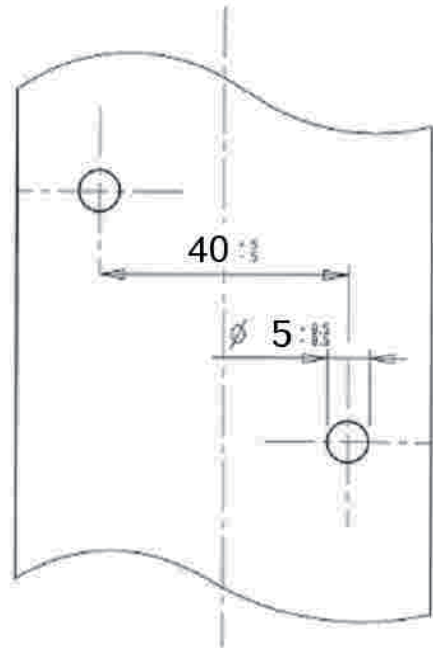

PHOTO DU PNEU MONTÉ SUR LA JANTE
PHOTO OF THE TYRE FITTED TO THE RIM

DESSIN DE LA BANDE DE ROULEMENT
TREAD DESIGN DRAWING

DESCRIPTIONS TECHNIQUES		TECHNICAL DESCRIPTIONS		
Sous une température de 23°C +/- 2°C, avec une humidité de 50% +/-5%		At a temperature of 23°C +/- 2°C and with a humidity of 50% +/-5%		
	Descriptions	Descriptions	Valeurs	Tolérances
	Dimensions	<i>Dimensions</i>	10x4.00-5	-
2	Désignation du mélange	<i>Tread compound designation</i>	MINI	-
3	Pression de Service	<i>Service pressure</i>	1,0 bar	+/- 0,3 bar
4	Pression de gonflage maximum	<i>Maximum inflation pressure</i>	4 bar	Max
5	Capacité de charge maximum	<i>Maximum load capacity</i>	80 Kg	Max
6	Vitesse maximale	<i>Maximum speed</i>	150 Km/h	Max
7	Rigidité latérale et verticale (sous charge de 40 kg)	<i>Lateral and vertical spring stiffness (under load of 40 kg)</i>	1,5 – 19	+/- 1 +/- 2
8	Rigidité latérale et verticale pour FE et ICE (sous charge de 50 kg)	<i>Lateral and vertical stiffness for FE & ICE (under load of 50 kg)</i>	-	-
9	Profondeur du profil	<i>Depth of tread</i>	5 mm	+/- 0,5 mm
10	Poids en grammes	<i>Weight in grams</i>	780 gr	+/- 5%
11	Nombre de plis	<i>Numbers of plies</i>	2	-
12	Épaisseur de la bande de roulement	<i>Tread thickness</i>	5.5 mm	+/- 1,0 mm
13	Nombre d'indicateurs d'usure du pneu	<i>Number of tread wear indicators</i>	6	-
14	Matériel de la carcasse	<i>Carcass material</i>	Polyestere	-
15	Angle de tissage de la toile du pneu	<i>Angle of tyre canvass</i>	34°	+/- 3°
16	Type du fil de tissage (Selon ISO)	<i>Canvass thread type (According to ISO)</i>	1100	-
17	Pneu tubeless	<i>Tubeless tyre</i>	YES	-
18	Dureté superficielle de la bande de roulement (ISO 48/94)	<i>Superficial tread hardness (ISO 48/94)</i>	60	+/- 5 DIDC IRHD
19	Abrasion en rotation (selon ISO 4649/02 Method B)	<i>Circular abrasion (according to ISO 4649/02 Method B)</i>	141	+/- 25 mm ³
20	Classification (selon ISO 4649/02 B)	<i>Classification (according to ISO 4649/02 B)</i>	SOFT	MEDIUM <u>HARD</u>

B DESSIN EN SECTION TRANSVERSALE ET MESURES DU PNEU MONTÉ SUR UNE JANTE

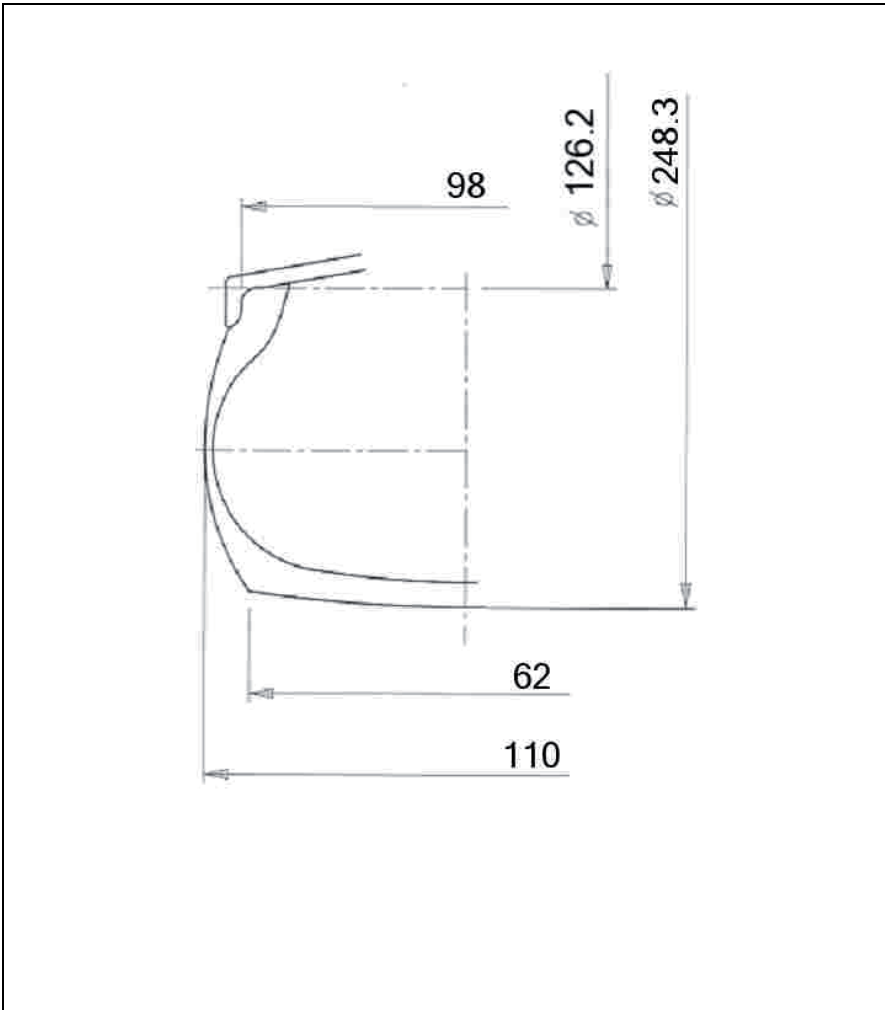

B DRAWING OF CROSS SECTION AND DIMENSIONS OF TYRE FITTED TO A RIM

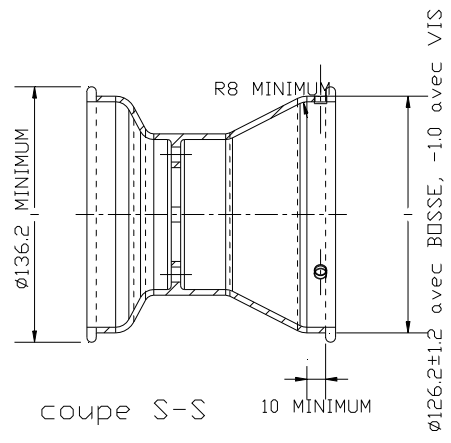
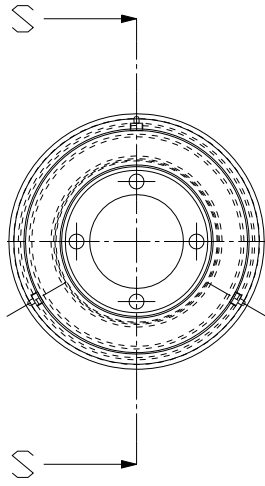

Tolérances Tolerances	
mm	mm
Diam. 126,2	+ 0 - 1
Diam. 248,3	+/- 6
98	+/- 3
62	+/- 5
110	+/- 5

Remarques
Comments



C	PHOTOS ET INSCRIPTIONS	Seules les inscriptions qui ne changeront pas tout au long de la fabrication sont reportées ci-dessous.		
C	PHOTOS AND INSCRIPTIONS	Only inscriptions which will not change during production are mentioned below.		
Photo du flanc extérieur du pneu <i>Photo of tyre external side wall</i>		Inscriptions sur le flanc extérieur du pneu <i>Inscriptions on tyre external side wall</i>		
		Texte <i>Text</i>	Hauteur <i>Height</i>	Trait <i>Stroke</i>
			mm	mm
		VEGA	13	3/8
		10x4.00-5	6,5	3
		MINI	6,5	3
		Max inflation pressure 4 bar	3,8	1
Toubless	3,8	1		
Photo du flanc intérieur du pneu <i>Photo of tyre internal side wall</i>		Inscriptions sur le flanc intérieur du pneu <i>Inscriptions on tyre internal side wall</i>		
		Texte <i>Text</i>	Hauteur <i>Height</i>	Trait <i>Stroke</i>
			mm	mm
		VEGA	13	3 / 8
		10x4.00-5	6,5	3
		KART >>	9,5	3
		made in Italy	3,8	1
For racing purpose only	3,8	1		