

Hour and minute hand clock

Analogue clocks

Profil 930

Description :

- ▶ Clock with analogue display.
- ▶ Hour - minute or hour - minute and second display.
- ▶ All DHF, AFNOR, NTP Supervised or radiosynchronized clocks include hand position control and automatic time set up.
- ▶ ABS casing IP 40, IK02.
- ▶ Optimal viewing distance : 20m
- ▶ Protective glass made with poly methacrylate.
- ▶ Casing colours: black, white, aluminium or chromium.
- ▶ Dial models: Arabic figures or minute notches.
- ▶ Wall bracket with optional locking system.



Technical features:

Movement	Power supply	Operating temperature	Weight
Quartz	1,5V LR6 battery	- 5°C to +50°C	0,7kg
DCF Radio	1,5V LR6 battery	- 5°C to +55°C	0,7kg
½ minute series rec.		-10°C to +50°C	0,9kg
24 V minute rec.		-10°C to +50°C	0,9kg
24 V second rec.		-10°C to +50°C	0,7kg
France Inter Radio	2x1,5V LR6 batteries	- 5°C to +50°C	0,7kg
Radio DHF rec.	2x1,5V LR6 batteries	- 5°C to +50°C	0,7kg
Radio DHF TBT rec.	6 to 16V DC	- 5°C to +50°C	0,7kg
NTP receiver PoE Supervised	via Ethernet, Class 0 device, 2W maximum	-5°C to +50°C	0,7kg
AFNOR TBT rec.	6 to 24V DC	-5°C to +50°C	0,7kg

Norms:

- ▶ Norm NF EN50081-1 : generic emission standard.
- ▶ Norm NF EN50082-1 and 50082-2: generic immunity standard.
- ▶ Norm NF EN55022 class B: radio disturbance of information technology equipment.
- ▶ Norm NF EN60950: Safety of information technology equipment.
- ▶ Norm NF EN300-220-3: radio equipment standard.
- ▶ Norm NF EN301-489-3: EMC standard for radio equipment
- ▶ Norm AFNOR NF S 87-500 C



Casing colours & dial



Optional chromium plated casing.



Double sided profil 930

References

HM

HMS

- | | | |
|-----------------------------------|---------|------------|
| ▶ Independent quartz on battery | | 981 11**1* |
| ▶ Radio synchronised DCF | | 981 311 |
| ▶ 24V second receiver | | 981 411 |
| ▶ 24V minute receiver | 981 511 | |
| ▶ 1/2 minute serial receiver | 981 611 | |
| ▶ France Inter radio synchronized | | 982 111 |
| ▶ DHF battery slave clock | 982 211 | 982 311 |
| ▶ DHF TBT slave clock | 982 411 | 982 511 |
| ▶ AFNOR TBT slave clock | 982 811 | 982 911 |
| ▶ NTP Supervised | 982 F11 | 982 G11 |

* Last figure of the reference number represents the casing colour:
1 = white, 2 = black, 3 = chromium, 5 = aluminium.
**Previous figure is the type of dial:
1 = figures, 2 = notches, 3 = Din.



Ref: 643191 M

Hour and minute hand clock

Analogue clocks

Profil 930

Single sided wall support

Mounting screws

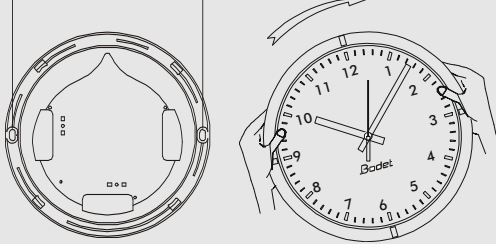

When the support is fixed on the wall, turn the clock a quarter turn in the clockwise so that the clock is in the correct position.

Double sided bracket mounting

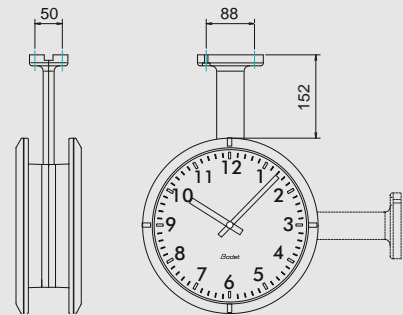

Movements and synchronisation:

Battery quartz autonomous movement with second hand

► The clock is totally independent, the time information comes from its own time basis. The operating temperature range of these clocks is -25°C to +55°C when using Lithium batteries.

FI or DCF radio synchronized autonomous movement

► The clock is totally independent. The France Inter or DCF radio synchronized movement brings absolute accuracy and automatic summer/winter changeovers.

IRIG-B/AFNOR coded time receiver

- The coded time distribution consists in transmitting a complete time message each second: the setting on time of the receivers is realised automatically and immediately after connection to the clock line.
- The IRIG-B/AFNOR coded time does not transmit interference and is insensitive to other electrical interference.

DHF receiver (norm AFNOR NF S 87-500)

► The DHF clocks pick up the radio signal and get automatically synchronised. If radio reception is poor, they keep on working on their own time basis.

24V minute impulse slave movement

► Slave clocks are connected to a distribution line and activated through electrical impulses sent every minute by the master clock.

24V second impulse slave movement

► Slave clocks are connected to a distribution line and activated through electrical impulses sent every second by the master clock.

1/2 minute serial impulse slave movement

► Slave clocks are connected to a distribution line and activated through electrical impulses sent every ½ minute by the master clock.

1.5V serial impulse slave movement (for BT radio)

► The slave clocks are connected to a radio synchronization box (BT radio) that generates electrical impulses every minute. The operating temperature range of these clocks is -25°C to +55°C but the operating temperature range of the box is -10°C to +50°C.

Network Time Protocol Supervised (NTP Supervised) slave movement

► The slave clocks are connected to the network Ethernet through IP addressing. The time synchronization is distributed from primary servers towards the network or master clock with unicast, multicast or by DHCP models.

Dimensions in mm

Hanging point

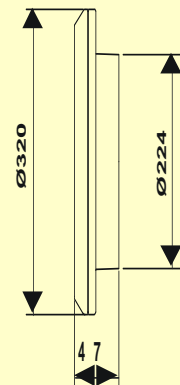
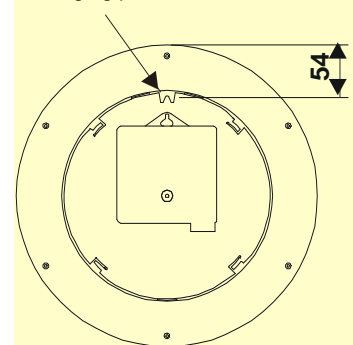

Mounting Accessories:

- | | |
|---|---------|
| ► Double sided bracket | 981 001 |
| ► Short double sided bracket | 981 002 |
| ► Secure wall fixing bracket for single sided clock | 981 006 |
| ► Power supply unit for battery-operated clock | 981 011 |
| ► 230V power supply with screw terminal for TBT clock | 938 914 |
| ► 230V power supply with mains plug for TBT clock | 938 916 |

