

EVERYTHING
SELLS BETTER
WITH A SYSTEM.

interior design systems
software and service

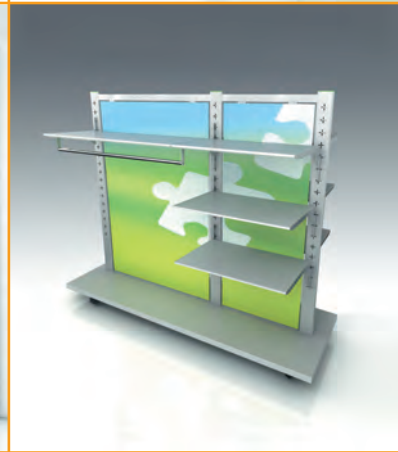

THE
WORLD
OF
SYSTEMS

OCTANORM 

INTERIOR DESIGN SYSTEMS

Thanks to the great variety of OCTANORM systems, designers, planners, architects and engineers are able to successfully realize their ideas and turn their visions into reality. OCTANORM systems are perfectly suited for the presentation of goods and/or services. They are true all-rounders at the Point of Sale. They can be combined with both traditional and modern materials which makes them very versatile and effective. Economically, the OCTANORM world of systems ensures that everything stays in line with the budget.

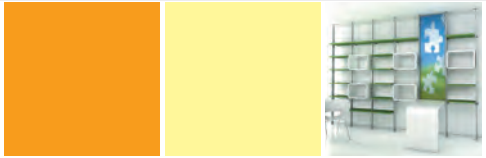

OCTAPLUS 1 (LATERAL VERSION)

SHELVES / MID-FLOOR FURNITURE / CLOTHES RACKS

1
4-5



OCTAPLUS 2 (FRONTAL VERSION)

SHELVES / WALL UNITS

2
6-7

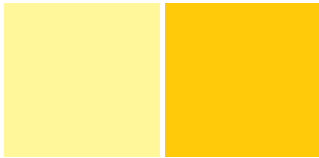

OCTAPLUS 3 (FRONTAL VERSION)

MID-FLOOR FURNITURE / CLOTHES RACKS

3
8-9

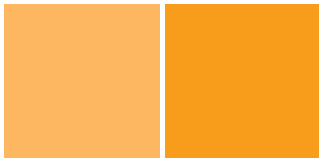

OCTAFRAME 1

SHELVES / WALL UNITS

4
10-11

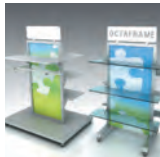

OCTAFRAME 2

MID-FLOOR FURNITURE / CLOTHES RACKS

5
12-13



NEWLINE SHOP 1 (PRODUCT RANGE S 3100)

SHELVES / MID-FLOOR FURNITURE / CLOTHES RACKS

6
14-15



NEWLINE SHOP 2 (PRODUCT RANGE S 6100)

SHELVES / MID-FLOOR FURNITURE / CLOTHES RACKS

7
16-17



MAXIMA LIGHT

SHELVES / PARTITION WALLS / ROOM DIVIDERS

8
18-19

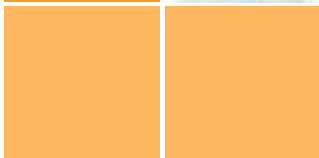

HORIZONTAL

SHELVES / MID-FLOOR FURNITURE

9
20-21



SLATWALL

SHELVES / MID-FLOOR FURNITURE

10
22-23



NEWLINE CORPUS

SHOWCASES / COUNTERS / PLATFORMS

11
24-25



NOTES

12
26-28



OCTADESIGN

PRESENTATION SOFTWARE FOR CREATIVE CONCEPTS

13

OCTAPLUS 1

SALES AND PRESENTATION FURNITURE

The shelves and mid-floor furniture designed with OCTAplus elliptical extrusions (lateral version) meet the highest expectations. Functional elements and other accessories such as shelves or cases seem to float between the uprights.



Components used: P 130, P 703, P 783, M 1395



Graphic elements can be handled easily



Simply hook in individual elements, no tools needed

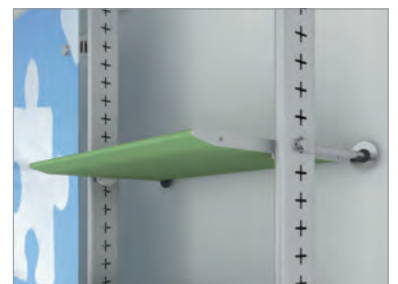

Wooden shelves increase the elegant appearance of the shelf unit

BASIC CONSTRUCTION:

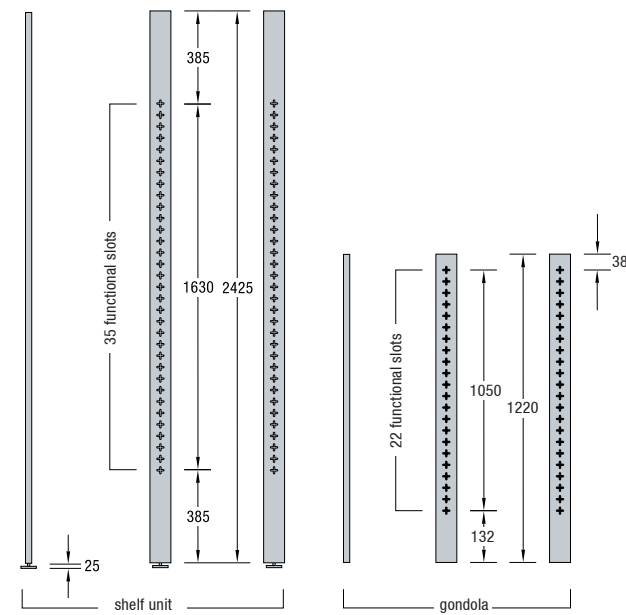

front left side right side

TECHNICAL DATA:

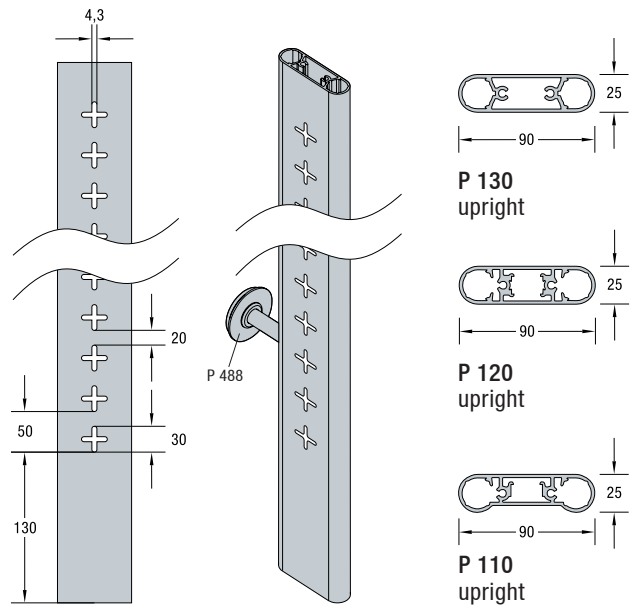

P 130 upright

P 120 upright

P 110 upright

SET-UP VERSIONS:

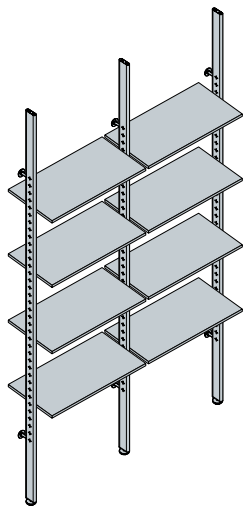

shelf unit

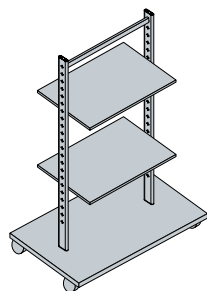

gondola with base plate

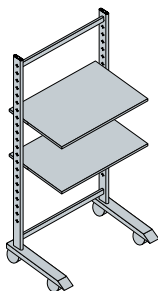

gondola with one-sided foot brackets S 144

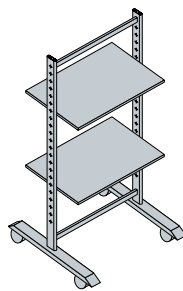

gondola with two-sided foot brackets S 146

EQUIPMENT DETAILS:

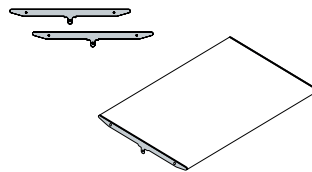

PP 703 shelf brackets, straight for postformed shelves, 1 pair

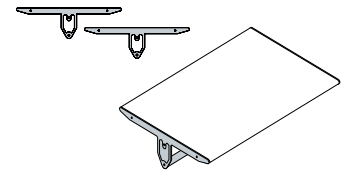

P 713 shelf brackets, straight for postformed shelves and clothes rail, 1 pair

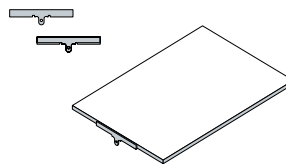

P 733 shelf brackets, straight for wooden shelves, 1 pair

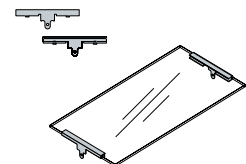

P 743 shelf brackets, straight for glass shelves, 1 pair

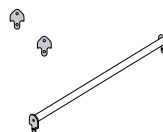

P 773 brackets, straight for clothesrail, 1 pair

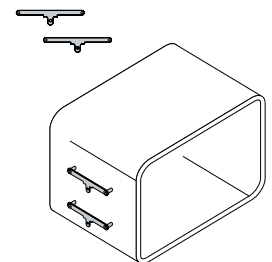

P 783 panel retainer for cases, 1 pair

OCTAPLUS 2 (SHELVES)

SALES AND PRESENTATION FURNITURE

The shelves designed with OCTAplus elliptical extrusions (frontal design) have an elegant appearance and feature a new hanging technique. A wide range of system accessories allows your imagination free rein, enabling you to realize many equipment and decoration ideas.



Components used: P 130, P 710 / P 950 / P 880 / P 886, P 740, P 790, P 806 / P 850, M 1458

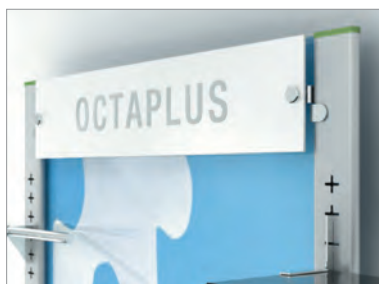

Easy hanging of signs and graphic covers



Brackets for shelves/clothes racks, also for individual axis dimensions



Distance piece adjustable to increase the dimensional effect

BASIC CONSTRUCTION:

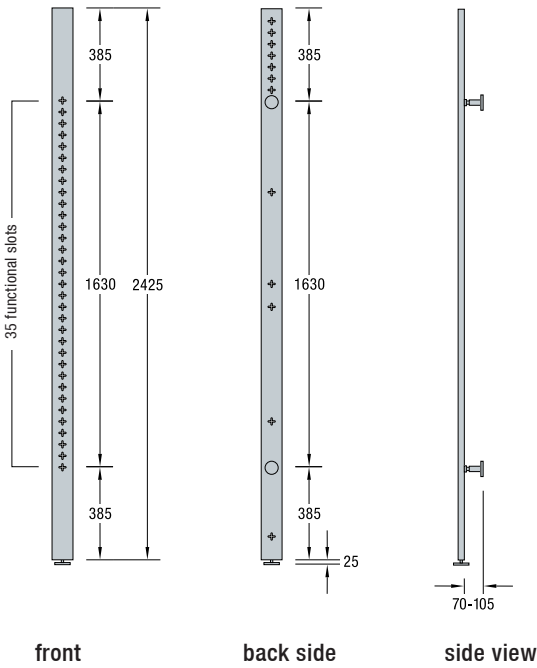

TECHNICAL DATA:

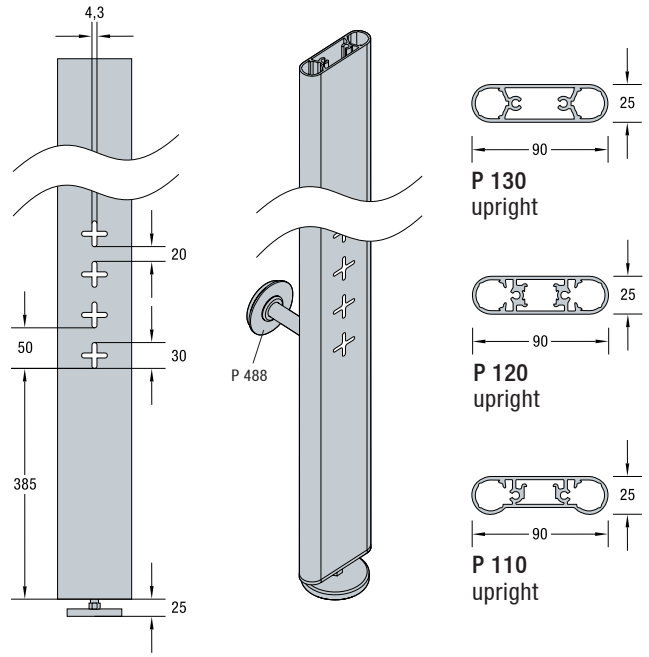

SET-UP VERSIONS:

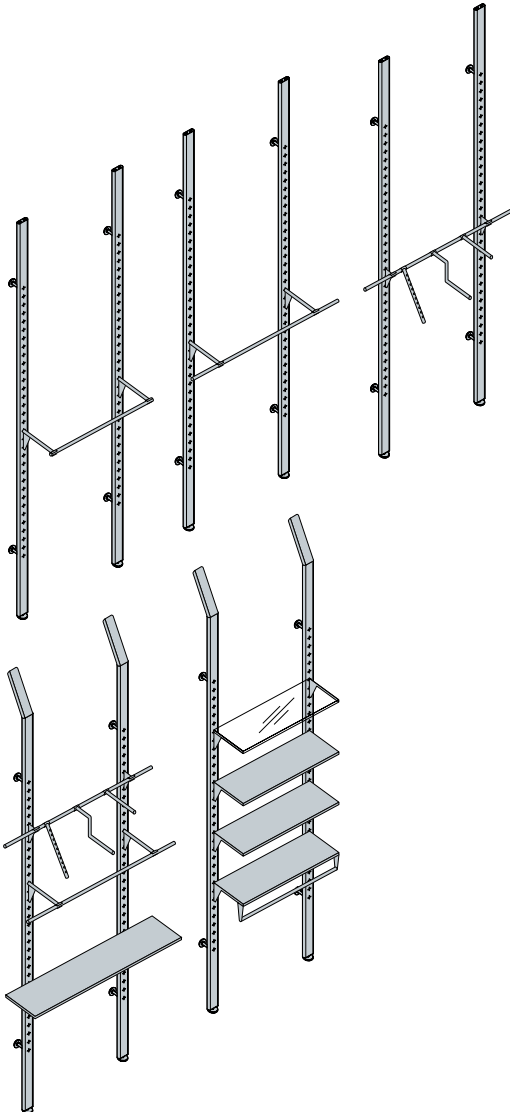

EQUIPMENT DETAILS:

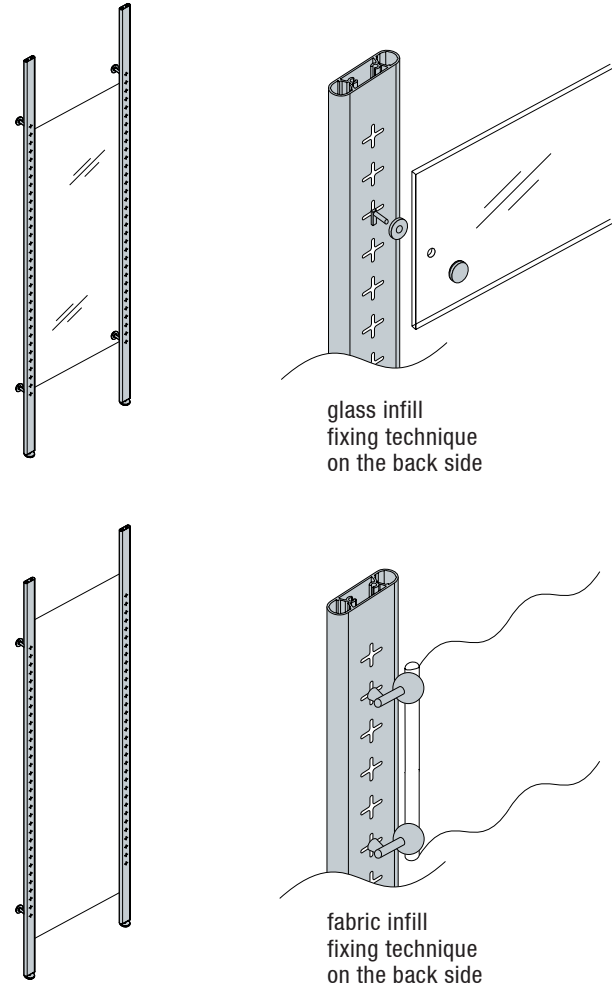

OCTAPLUS 3

MID-FLOOR FURNITURE / CLOTHES RACKS

With regard to equipment and decoration, our mid-floor furniture is as alterable as our shelf units and can be used to represent the Corporate Identity of a company or a brand. Our system offers the solutions for almost every thinkable creation.

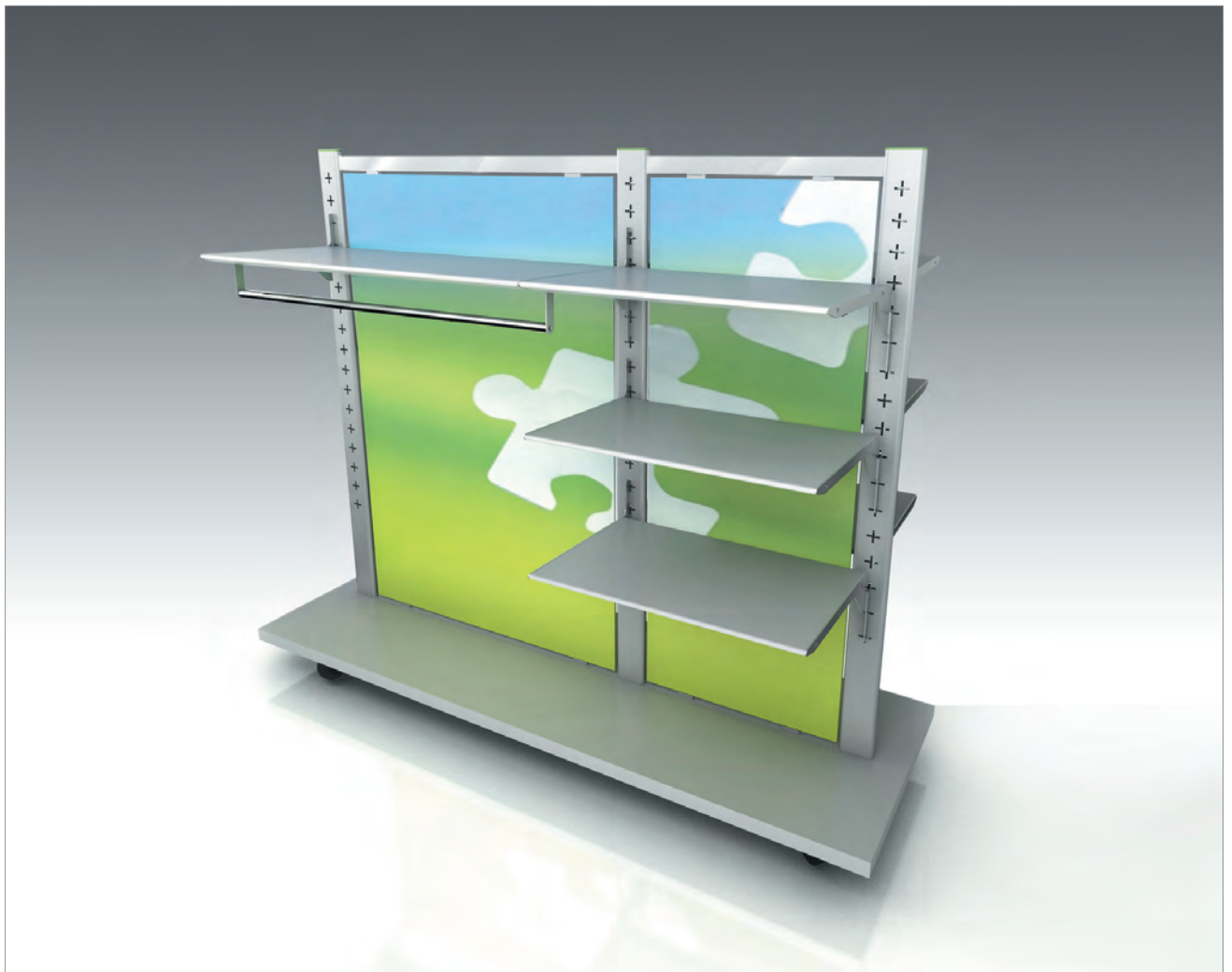

Components used: P 130, Z 4400, P 700/P 710/P 950/P 880/P 889



The universal bracket accommodates folded goods as well as hanging goods



The cross-slot hooking in technique firmly holds shelves and accessories

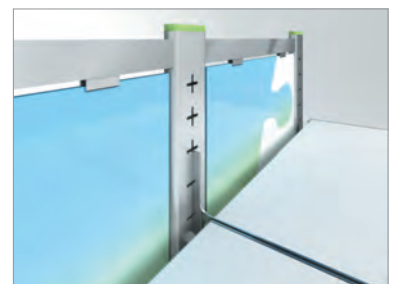

Firm support for wall panels made of different materials

BASIC CONSTRUCTION:

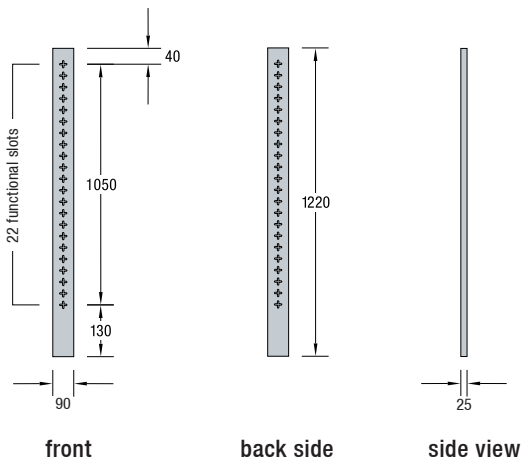

TECHNICAL DATA:

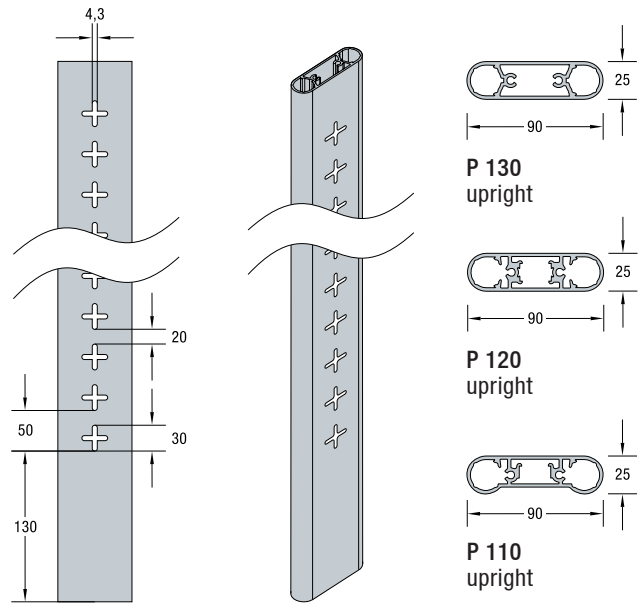

SET-UP VERSIONS:

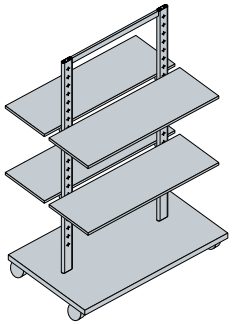

gondola with two-sided base plate

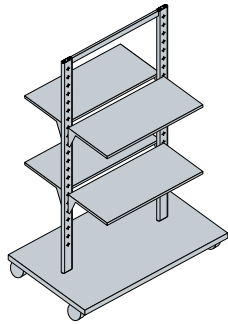

gondola with two-sided base plate

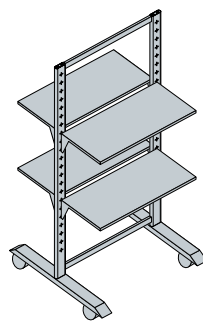

gondola with two-sided foot bracket S 146

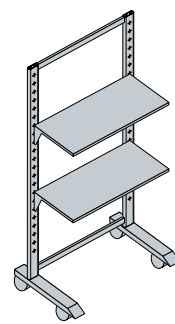

gondola with one-sided foot bracket S 144

EQUIPMENT DETAILS:

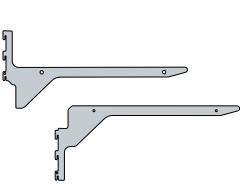

P 700
shelf bracket for postformed shelves, 1 pair

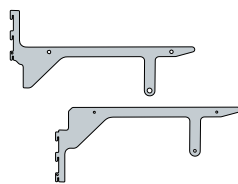

P 710
shelf bracket for postformed shelves and clothes rail, 1 pair

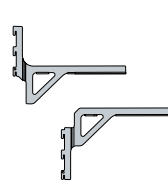

P 730
shelf bracket for wooden shelves, 1 pair

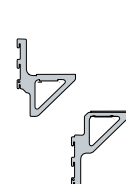

P 740
shelf bracket for glass shelves, 1 pair

OCTAFRAME 1

SALES AND PRESENTATION FURNITURE

The frame construction of our OCTAFRAME product range consisting of 40x40mm square profiles with small functional grooves allows for many different configurations. Thanks to the quick and easy exchangeability of the elements your furniture can be given a new look every now and then.



Components used: M 1000-25S1, P 730, floor units (V 2000 product range), light boxes (M 1800 product range)

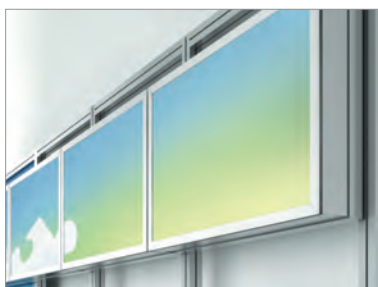

Light boxes for shelf units; graphic panels can be exchanged without tools



Mounted directly in the system groove: panels with a thickness of up to 4 mm



Wall and floor units made of the V 2000 product range



BASIC CONSTRUCTION:

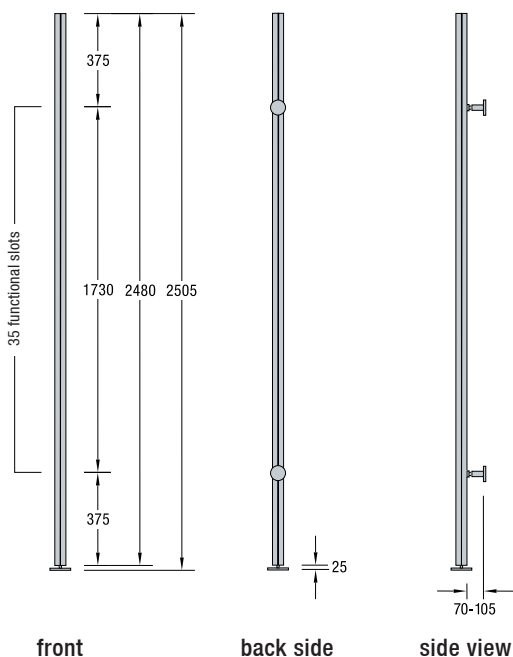

TECHNICAL DATA:

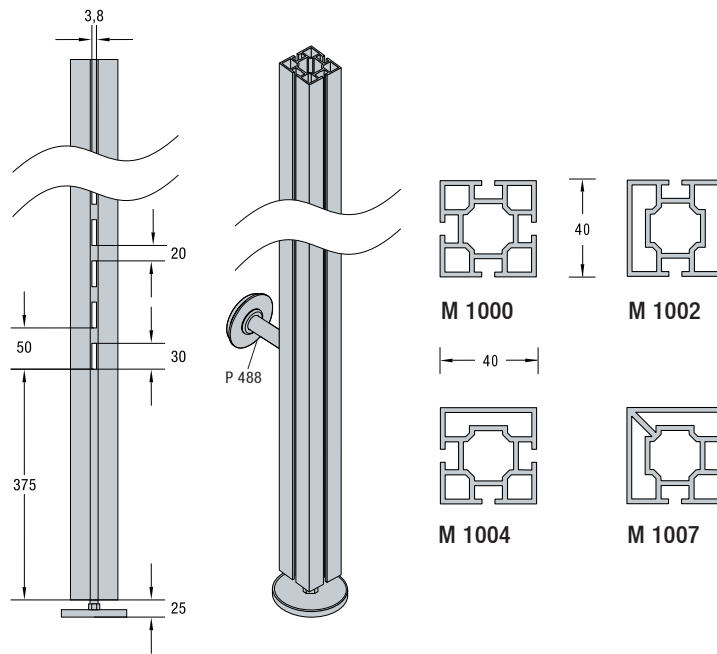

SET-UP VERSIONS:

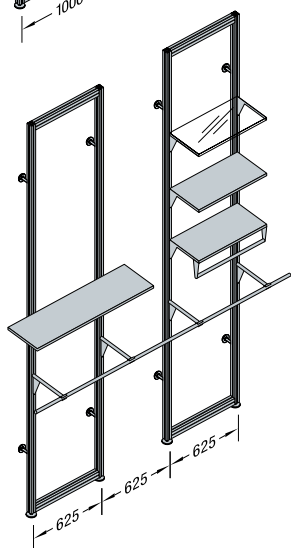
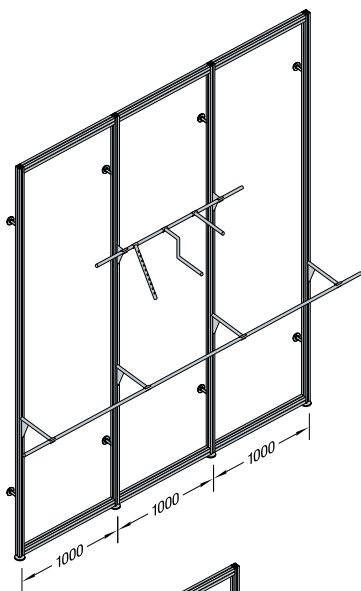

EQUIPMENT DETAILS:

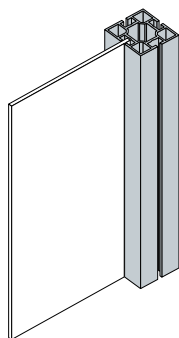

4.3 mm groove
direct insertion of
panels up to 4 mm

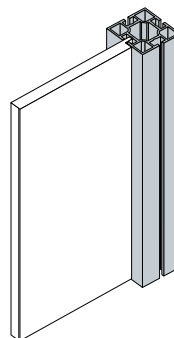

4.3 mm groove
for tongue and groove
panels, variable thickness

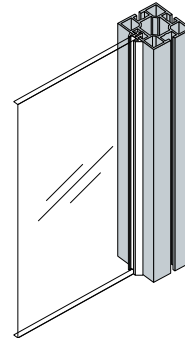

E 424
glass retainer, panel
thickness 4 to 6 mm

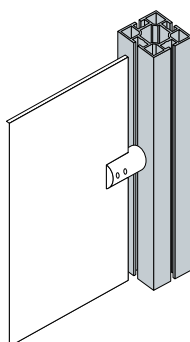

M 1456
panel retainer, panel
thickness 4 to 8 mm

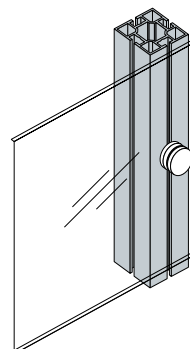

M 1391 / M 1392
glass panel retainer,
panel thickness
5 - 10 mm (glass) and
5 - 14 mm (panels)

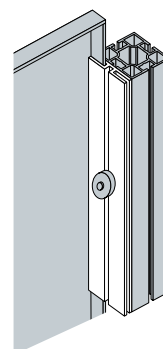

M 1310
fabric suspension
extrusion 40 mm

M 1345
fixing set M6

Please also see page 26.

OCTAFRAME 2

MID-FLOOR FURNITURE / CLOTHES RACKS

Mid-floor furniture with guaranteed mobility. – The OCTAFRAME construction combines the classy look of aluminium extrusions with a great variety of configurations thanks to the compatibility of its components with the OCTANORM system program.

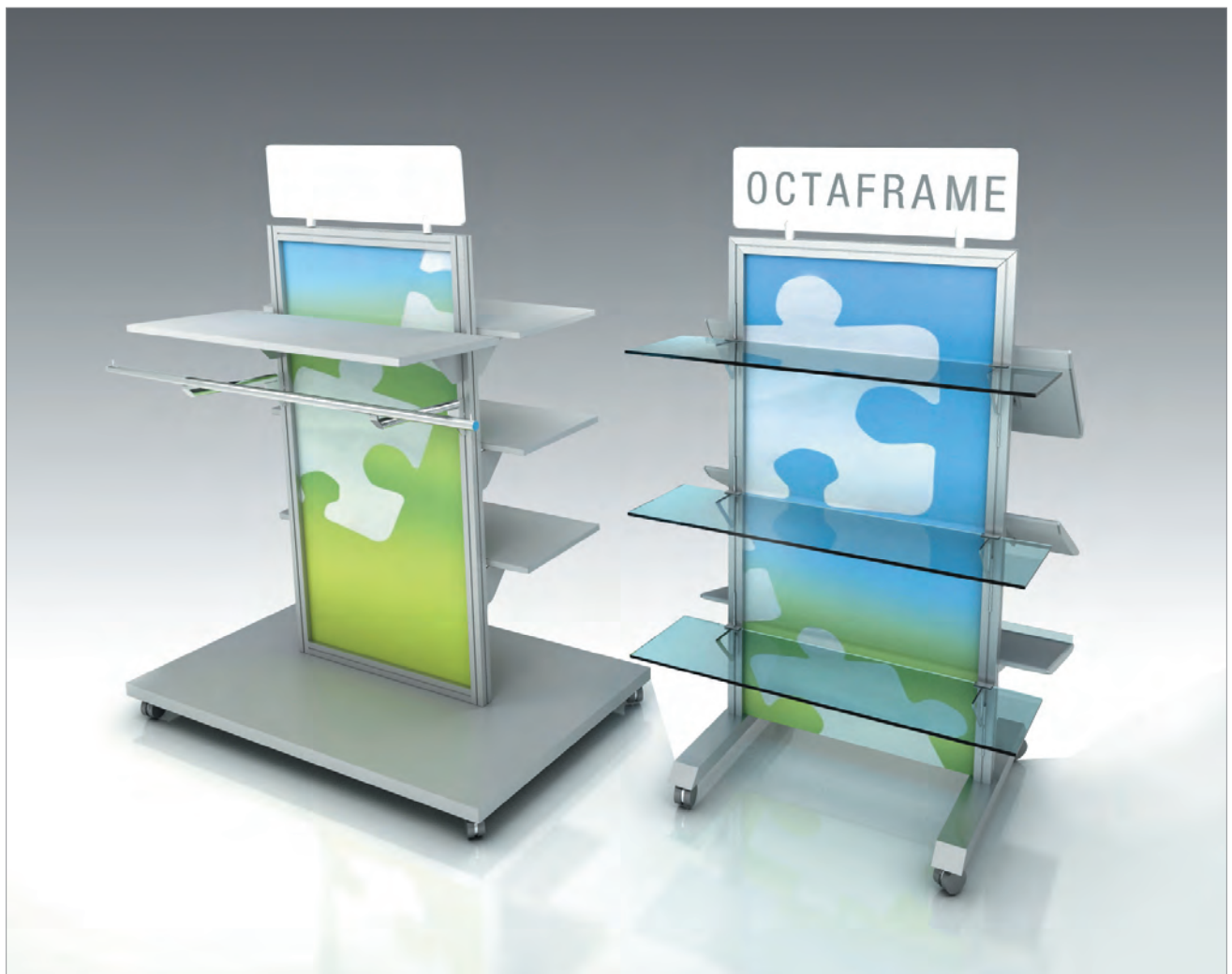

Components used: M 1000, foot bracket, P 720, P 806, P 750, M 1458



Attachment of signs and graphic covers



Accessories (independent of axes)
add to the effective area

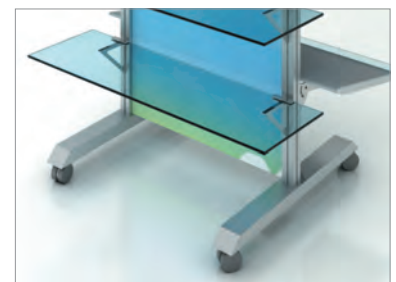

Foot brackets are available as an
alternative to the base plate

BASIC CONSTRUCTION:

TECHNICAL DATA:

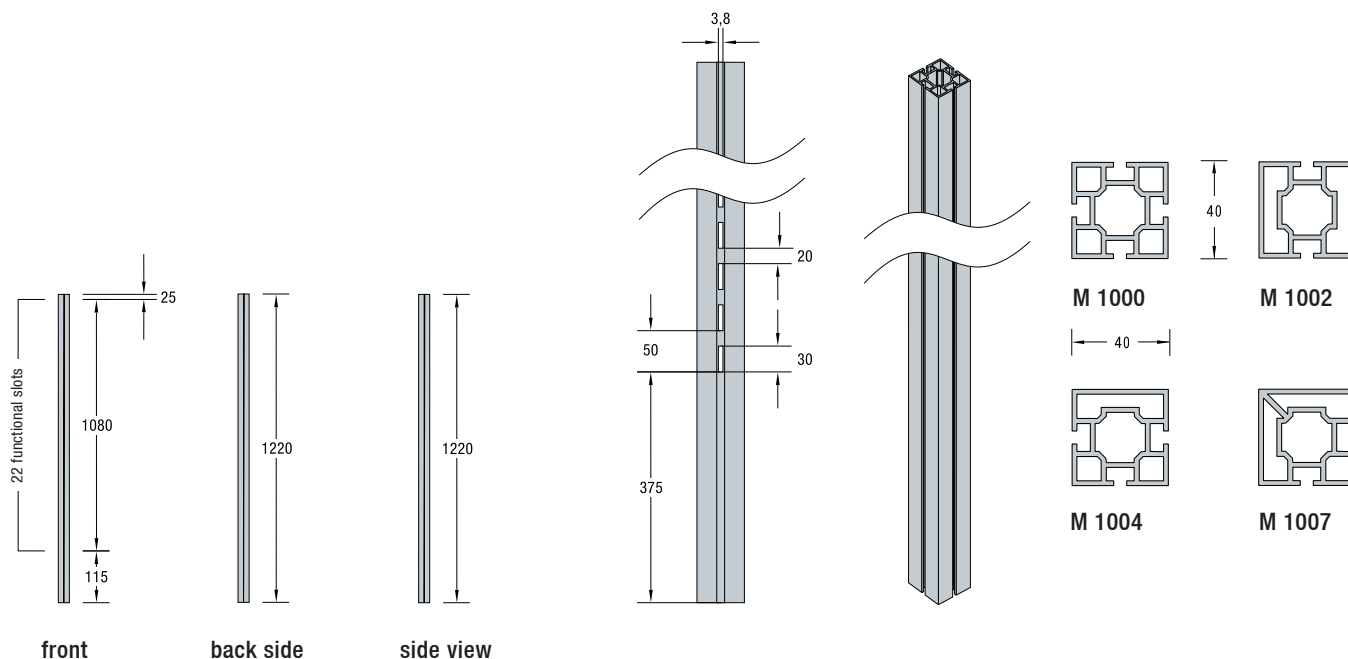

SET-UP VERSIONS:

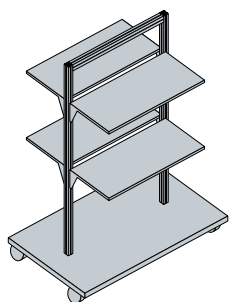

gondola with two-sided base plate

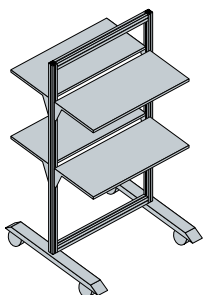

gondola with two-sided foot bracket S 146

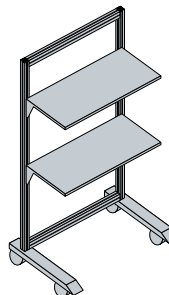

gondola with one-sided foot bracket S 144

EQUIPMENT DETAILS:

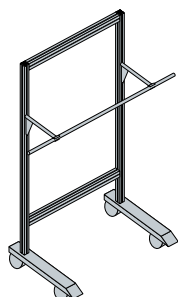

gondola with one-sided clothes rail

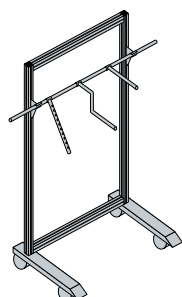

gondola with one-sided bar

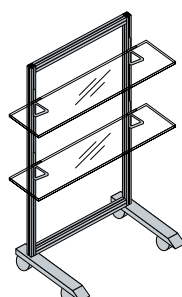

gondola with glass shelves, overhanging

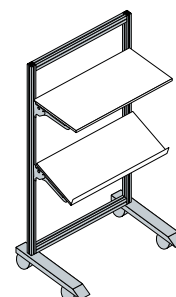

gondola with bracket P 725 shelves with variable inclination

Please also see page 26.

NEWLINE SHOP 1

SALESROOM DESIGN FOR WALL AND MID-FLOOR

The elegance of anodized aluminium extrusions combined with a slotted rail system made of high-class stainless steel and with a 10x10 mm linear pattern – that's the core message of our newlineSHOP product range.



Components used: S 6100 / S 4100 / Z 308, S 4210 / S 4211, S 4330, S 4312 / M 1237, E 2150 / E 2155 / E 2160, E 2179 / E 2175 / E 2180, showcase (V 2000 product range)



slotted insert rail S 4100
in aluminium extrusion S 3100

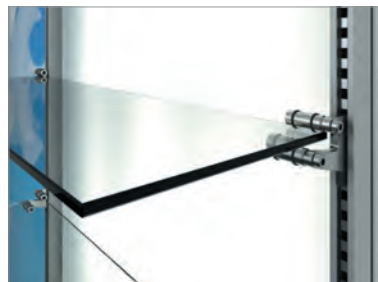

Shelf bracket E 2160



Adjustable foot S 4312 and
base plate M 1237 for leveling



BASIC CONSTRUCTION:

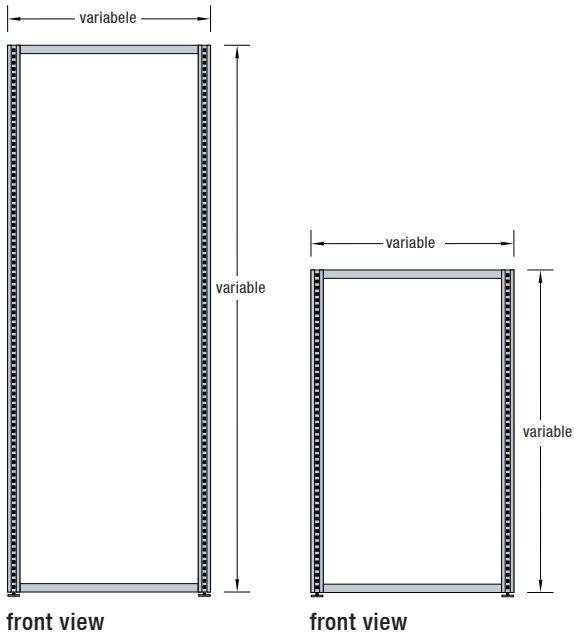

TECHNICAL DATA:

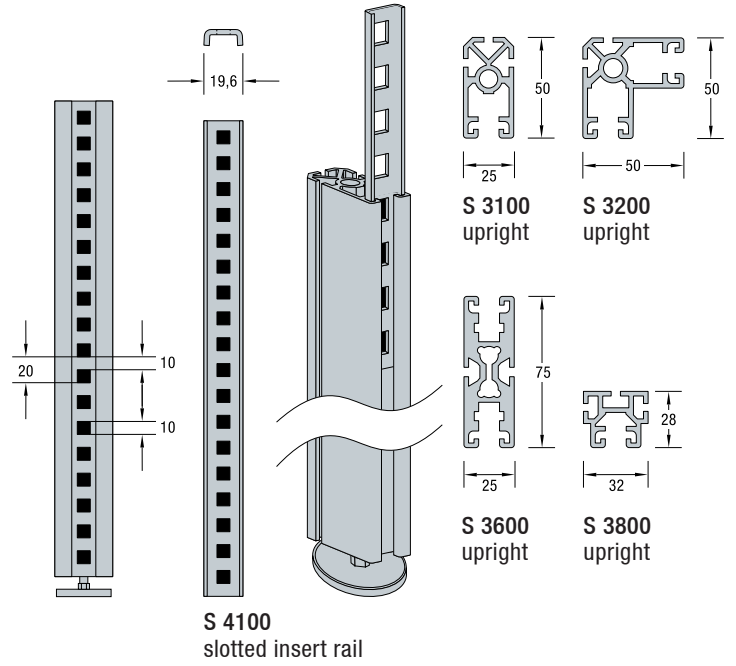

SET-UP VERSIONS / EQUIPMENT DETAILS:

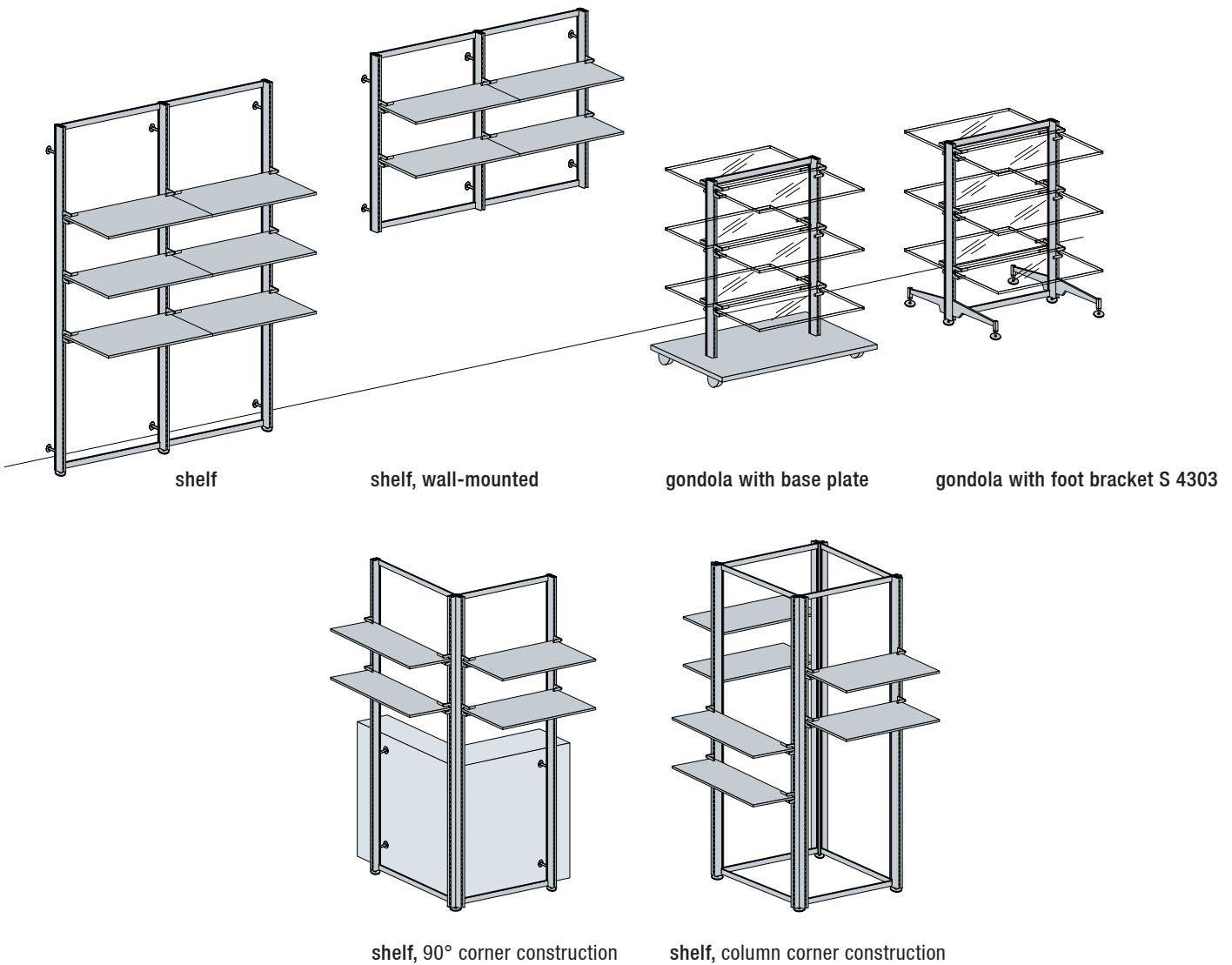

NEWLINE SHOP 2

SALES AND PRESENTATION FURNITURE

Exceptional lightness and elegance – that's what defines the appearance of the elliptical extrusions of our newlineSHOP S 6100 / S 6105 product range. Thanks to a great variety of system accessories, the line is of particular interest for many markets and applications.



Components used: S 6105, S 6130, S 6240/S 6241, E 719/E 718

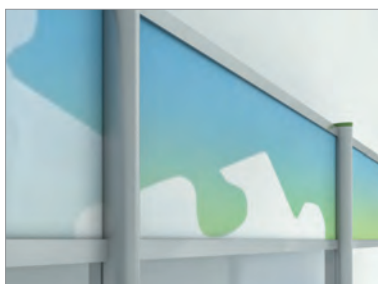

Horizontal beams facilitate the exchange of graphic panels



Design example: glass shelf



Wall distance piece for variable depths and uneven walls



BASIC CONSTRUCTION:

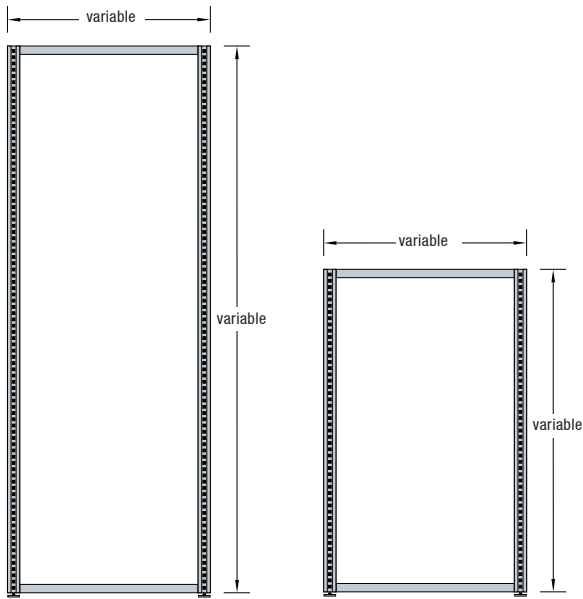

front view

front view

TECHNICAL DATA:

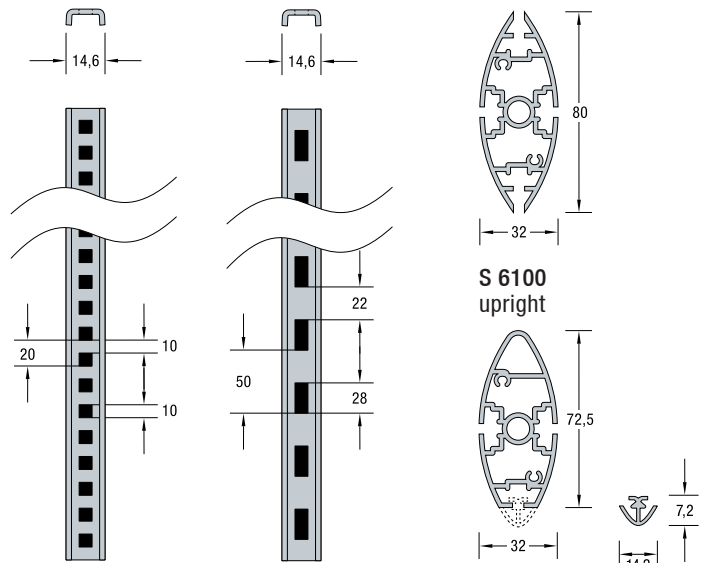

S 6200
slotted insert rail

S 6300
slotted insert rail

S 6100
upright

S 6105
upright

S 6110
upright

SET-UP VERSIONS:

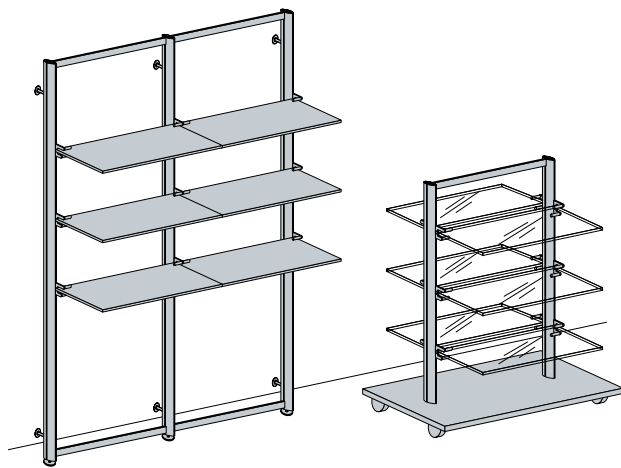

shelf

Gondola with base plate

EQUIPMENT DETAILS:

FOR UPRIGHT, WITH SLOTTED INSERT RAIL S 6200

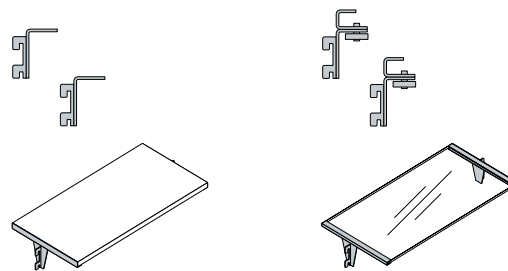

S 6218
bracket for wooden
shelf, steel, 1 pair

S 6220
bracket for glass
shelf, steel, 1 pair

EQUIPMENT DETAILS:

FOR UPRIGHT, WITH SLOTTED INSERT RAIL S 6300

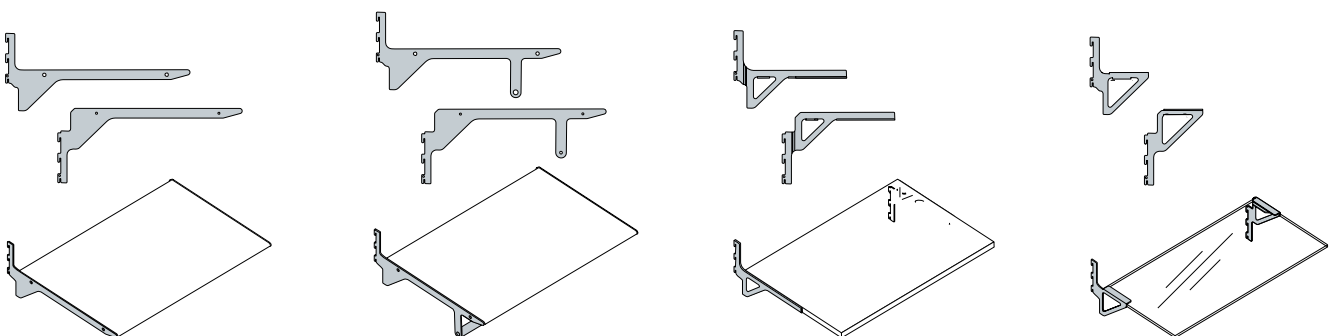

P 700
shelf bracket for
postformed shelves,
1 pair

P 710
shelf bracket for
postformed shelves and
clothes rail, 1 pair

P 730
shelf bracket for
wooden shelves,
1 pair

P 740
shelf bracket for
glass shelves,
1 pair



MAXIMA LIGHT

INDIVIDUAL WALL DESIGNS

No matter if you look for shear walls with multidimensional presentation space as shown below, a frame construction for shelves, some mid-floor furniture or even a building set with special functions – the extrusions of our MAXIMA light product range prove to be true masters of metamorphosis.



Components used: base frame (M 1020, M 1038, M 1065, M 1114/M 1116), fabric frame (M 1000, P 478, P 806, P 750) and horizontal frame (M 1000, P 478, H 225/H 230, MF 240, MF 306)



Fabric back panel with clip fastening



Movable functional wall



Quick and solid connection of base and functional frame



BASIC CONSTRUCTION / PROFILE CONNECTIONS:

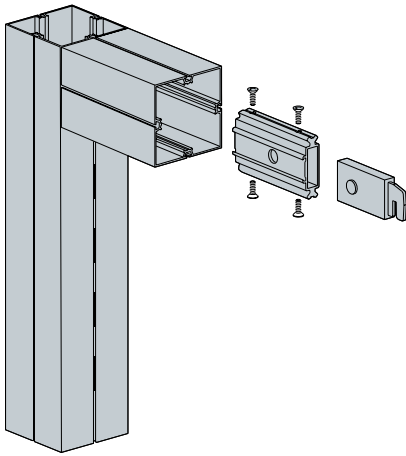

M 1114 (right) / M 1116 (left)
Connection with safety tension lock, adjustable in height according to grid system

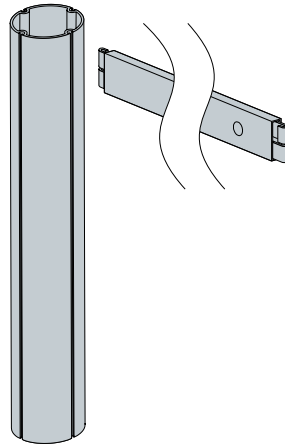

Z 961/13
Connection with tension lock, infinitely adjustable in height

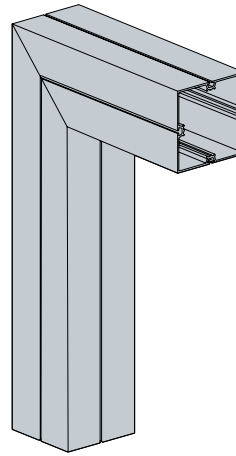

Miter connection with square extrusion

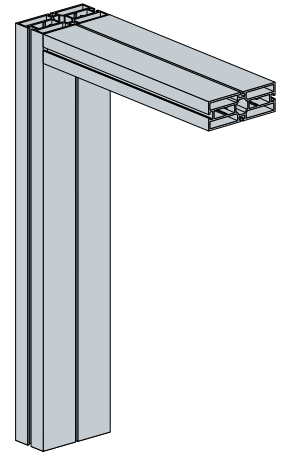

Connection with rectangular extrusion

EXTRUSION VARIANTS:

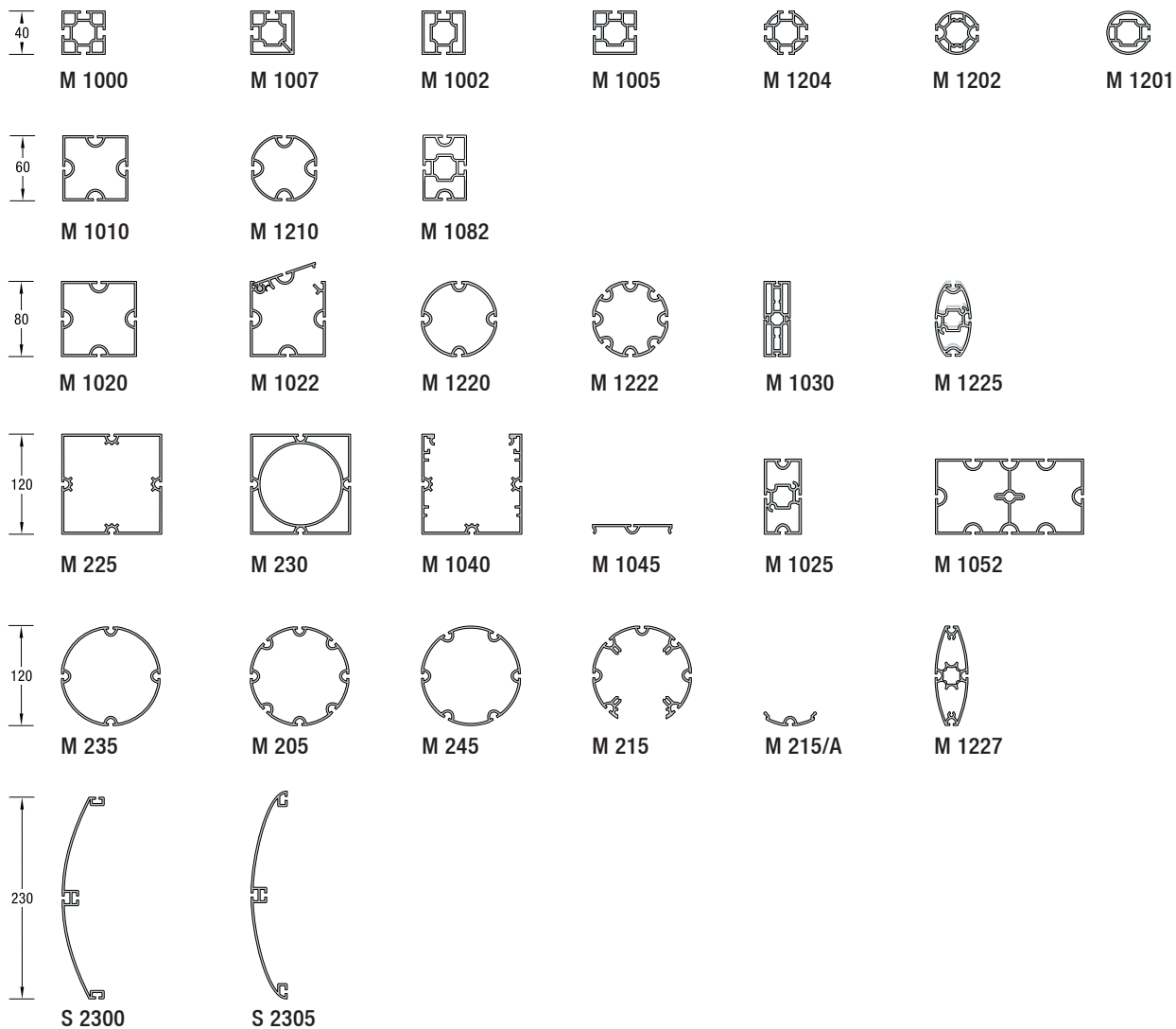

HORIZONTAL

FUNCTIONAL WALLS WITH DECORATIVE SCOPE

In addition to shelving systems with vertical slotted insert rails, horizontal presentation facilities are of particular importance for many markets. The OCTANORM HORIZONTAL product range offers the possibility of building graphics-capable and backlit functional walls with high-class accessories.



Components used: M 1000, M 1457, H 220, H 225, slatwall accessories, showcase (V 2000 product range)



Attractive design possibilities through insertion technique



Glass shelf retainer



Stability due to hinge mountings



BASIC CONSTRUCTION:

TECHNICAL DATA:

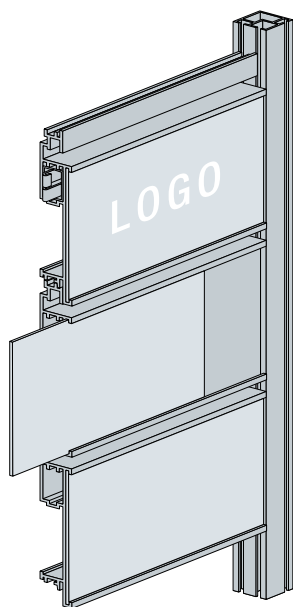

H 100
extrusion

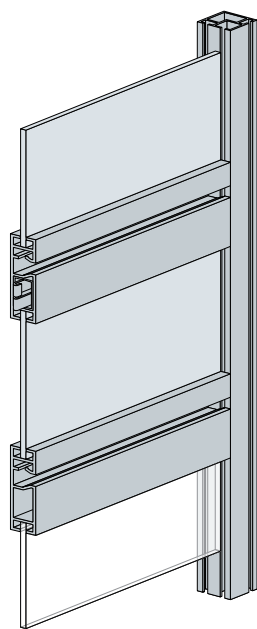

H 205
extrusion

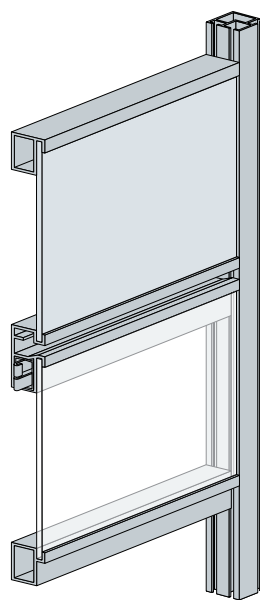

H 225 and H 230
extrusion

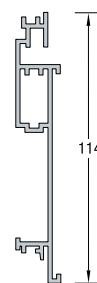

H 100
extrusion

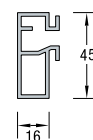

H 230
extrusion

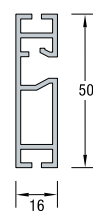

H 210
extrusion

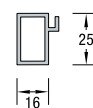

H 225
extrusion

EQUIPMENT DETAILS (MERCHANDISE SUPPORT):



H 310 *
round rod
300 mm



H 315 *
round rod
150 mm



H 320*
bracket for
wooden shelves
250 mm

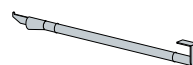

H 321*
bracket for
glass shelves
250 mm



H 420 *
pre-pack bracket
200 mm



MF 209
single hock
200 mm

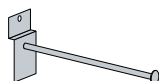

MF 236
single hock with
slipguard, 200 mm



MF 226
double hock,
200 mm



MF 228/A
suspension device
for cases

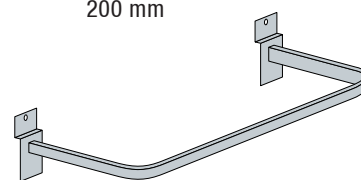

MF 220
clothes frame
600 x 300 mm

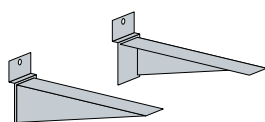

MF 212
bracket for wooden shelves
1 pair

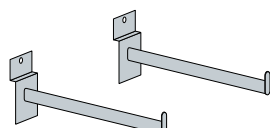

MF 231
bracket for glass
shelves, 200 mm deep
1 pair



MF 306
bracket for glass shelves,
variable depth

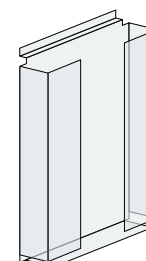

PF 117
literature holder
DIN A4

* Only for H 100.

Extrusions H 220, H 225 and accessories with item N° MF ... are not available from stock. Request lead time.



SLATWALL

HORIZONTAL WALLS WITH A WIDE VARIETY OF OPTIONS

Walls with horizontal grooves permit the presentation of different choices of goods in small formats and in packages in individual sections. Our SLATWALL product range is perfectly suited for this kind of application and can also be combined freely with other elements of our OCTANORM program.



Components used: M 1000, E 429, SP 705, slatwall accessories, theme frame (S 2305, also see page 19)



Monitor Mount MF 228/A



Frame design consisting of oval extrusion S 2305



Brackets for wooden and glass shelves



BASIC CONSTRUCTION / TECHNICAL DATA:

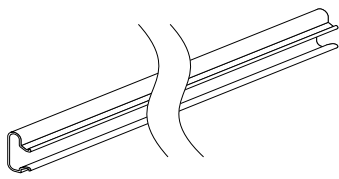

PF 901-908
PVC

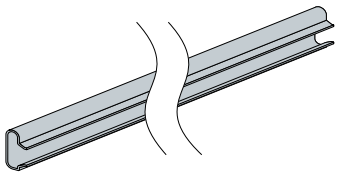

AF 805
aluminium

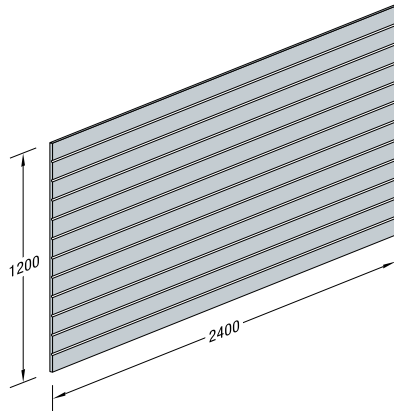

slatted wall
landscape format

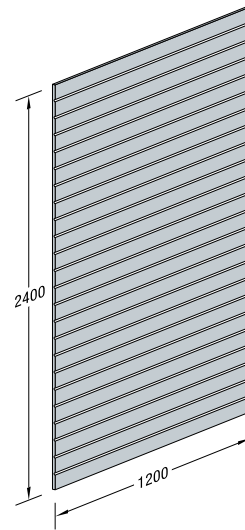

slatted wall
portrait format

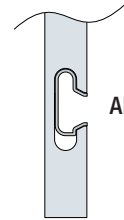

slatted wall
sideview

AF 805

PANEL CONNECTIONS:

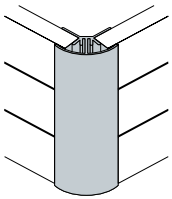

MF 259
connector extrusion,
rounded, anodized

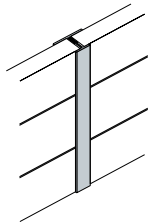

MF 290
connector extrusion,
in-line construction,
anodized

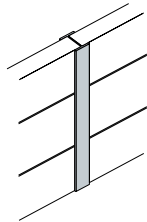

PF 168 - PF 170
connector extrusion,
in-line construction,
PVC

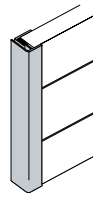

MF 294
flange extrusion,
aluminium,
anodized

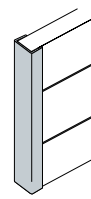

PF 172 - PF 173
flange extrusion,
PVC

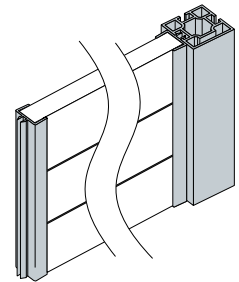

E 429
extrusion connector
to OCTANORM system
groove

EQUIPMENT DETAILS:



MF 209
single hook,
200 mm



MF 236
single hook with
slipguard, 200 mm



MF 226
double hook,
200 mm



MF 228/A
suspension device
for cases

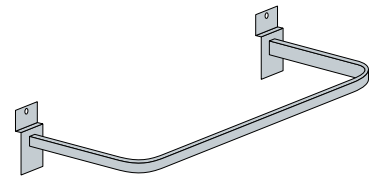

MF 220
clothes frame
600 x 300 mm

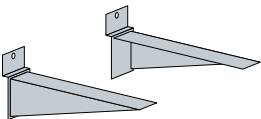

MF 212
bracket for wooden shelves,
1 pair

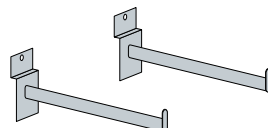

MF 231
bracket for glass shelves,
200 mm deep, 1 pair



MF 306
bracket for glass shelves,
variable depth

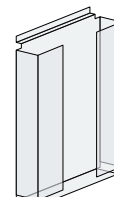

PF 117
literature holder
DIN A4

This category of goods is not available from stock. Request lead time.

NEWLINE CORPUS

MID-FLOOR DESIGN AND INDIVIDUAL FURNITURE

For many jobs and purposes, solid and stylish mid-floor furniture such as counters, showcases, platforms, column linings and the like, is of prime importance. Our newlineCORPUS product range offers you 21 different extrusion shapes and dimensions along with a number of system accessories. An OCTANORM classic, of timeless beauty and high utility value.



Components used: V 2000, V 2070, Z 4400, fittings for hinged doors



Accessories for hinged and sliding doors are adapted to the profile dimensions

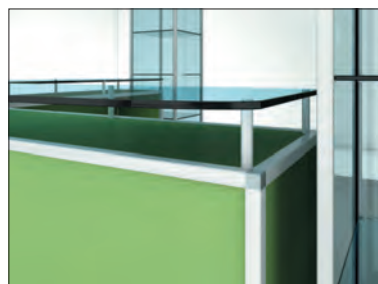

Aluminium extrusions and zinc diecast corner connectors



Infinitely adjustable shelves



BASIC CONSTRUCTION / TECHNICAL DATA:

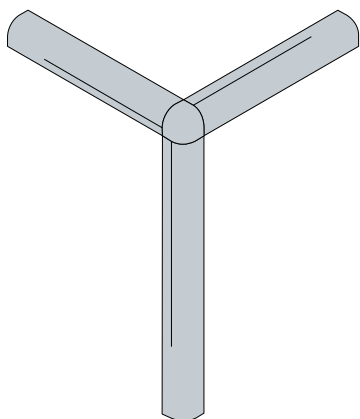

corner solution, version 1
S 1105
extrusion with 90° corner connection,
corner connector S 1170

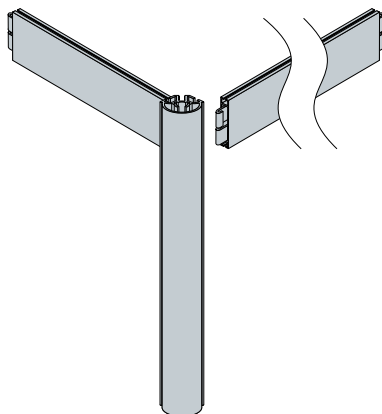

corner solution, version 2
S 1200
extrusion with 90° beam connection,
beam extrusion Z 4400

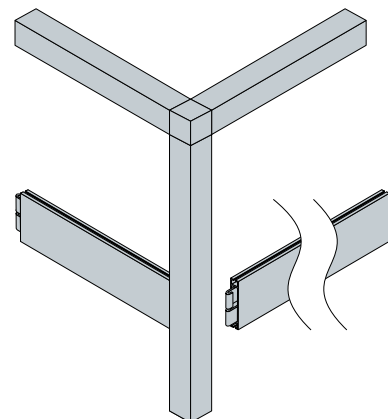

S 1125
extrusion with 90° corner connection,
corner connector S 1190 and
beam extrusion Z 4400

EXTRUSION VARIANTS:

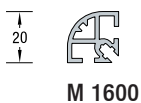

M 1600

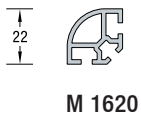

M 1620



M 1622



M 1625

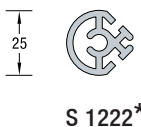

S 1222*

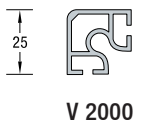

V 2000

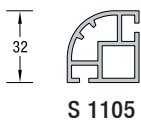

S 1105



S 1303



S 1125



S 1200*



V 2005

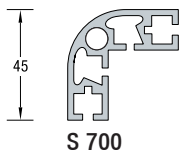

S 700

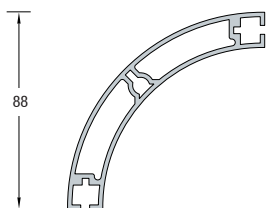

S 600

The counter / showcase group shown on page 24 can also be constructed with different extrusion shapes and dimensions. Measurements are variable and based on individual requirements.

* Extrusions S 1200 and S 1222 are connected as shown in corner solution version 2.

NOTES

EVERYTHING SELLS BETTER WITH A SYSTEM

The theme groups 1 to 11 in this brochure feature a number of salesroom design examples. 11 convincing solutions based on the different product ranges of our wide and comprehensive OCTANORM delivery program. What they have in common is that our shopfitting and interior design systems offer all required basic components for an individual and modern salesroom design. This results in harmonious shop and project furnishings, extraordinary shop-in-shop solutions, eye-catching island units or most functional single furniture. Including, of course, ultimate individuality and flexibility.

Additional Information:

For design examples shown on pages 10-14 and 18-19, alternative profile groups in other dimensions are available. Upon request, they can be supplied with the typical OCTAFRAME functional slots.

Extrusions that can be supplied with oblong functional slots:

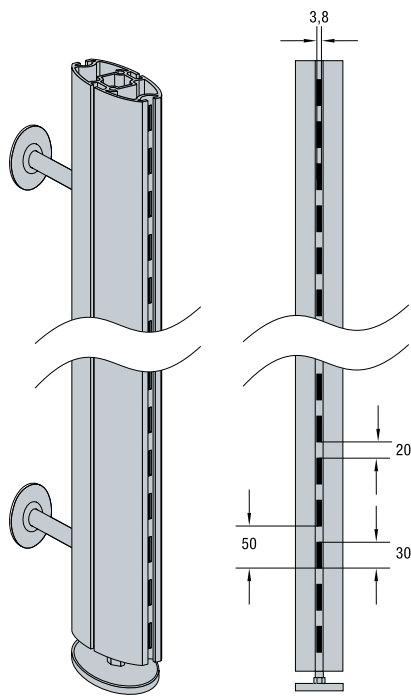

example M 1225

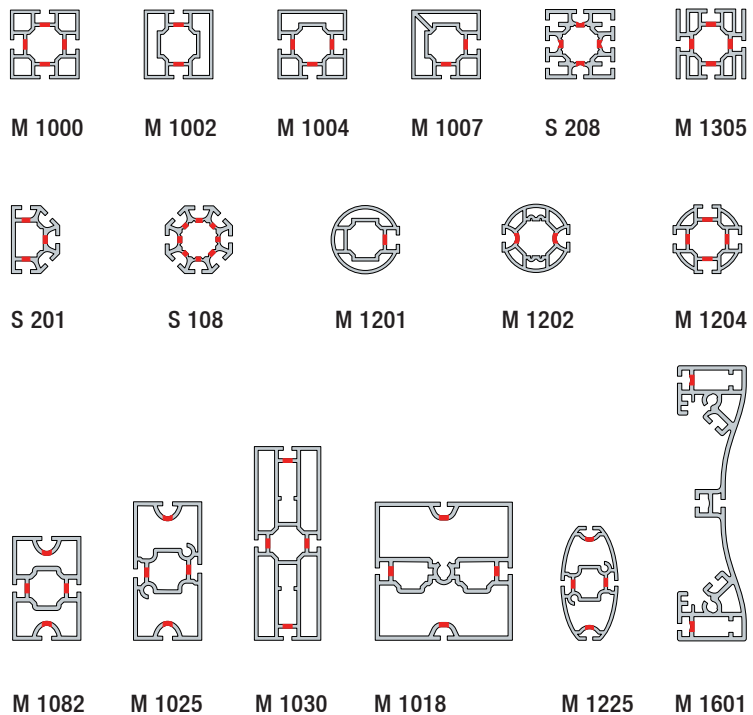

Caption: **I** = oblong functional slot possible

OCTADESIGN

PROFESSIONALS GO FOR THIS SOFTWARE

The key to a successful and engaging presentation is the initial creative concept. There is often a danger that the creative vision can be lost due to technical restraints on detail. OCTAdesign is a presentation software that accommodates the creativity of the designer. It offers a great variety of constructional possibilities and presentation features that include slides, panorama pictures, and virtual reality. This software not only encourages the imagination of the designer, but also accounts for budget control, parts list and audit, making OCTAdesign the essential presentation tool for any design agency.



* All photorealistic pictures shown in this brochures were created with our OCTAdesign presentation software.

**FOR MORE DETAILS ON OUR SOFTWARE PRODUCTS
AND SERVICES PLEASE CONTACT US.**

HOTLINE: +49 (711) 77 00 3-42 / FAX: +49 (711) 77 00 3-53 / E-MAIL: j-kopf@octanorm.de

• FUNCTION
& FORM - THAT'S
OCTANORM.

exhibition systems
interior design systems
presentation systems
cleanroom systems
software and service

• FAR BEYOND THE NORM:
INTERIOR DESIGN SYSTEMS FROM
OCTANORM.

Would you like a quotation? More information? An appointment?
We look forward to your call, your query and you! Welcome to OCTANORM.

AW 402.GB_05/2010

THE
WORLD
OF
SYSTEMS

www.octanorm.com

OCTANORM 