

SPACEWALL®
SLIM.

shopfitting systems



THE
WORLD
OF
SYSTEMS

OCTANORM®
NORDIC



.INTRODUCTION.

INTRODUCING SPACEWALL® SLIM, NEW SLAT WALL SYSTEM!

With Spacewall® Slim you have the option of a “classic” slat wall in a sophisticated visual appearance. In the same way as conventional slat walls you are well familiar with, but with an opening of only 4mm, the Spacewall® Slim panels and profiles create an elegant ambience without losing load capacity. Add the elegant and functional Slim accessories in satin chrome, metal and highly transparent plastics.

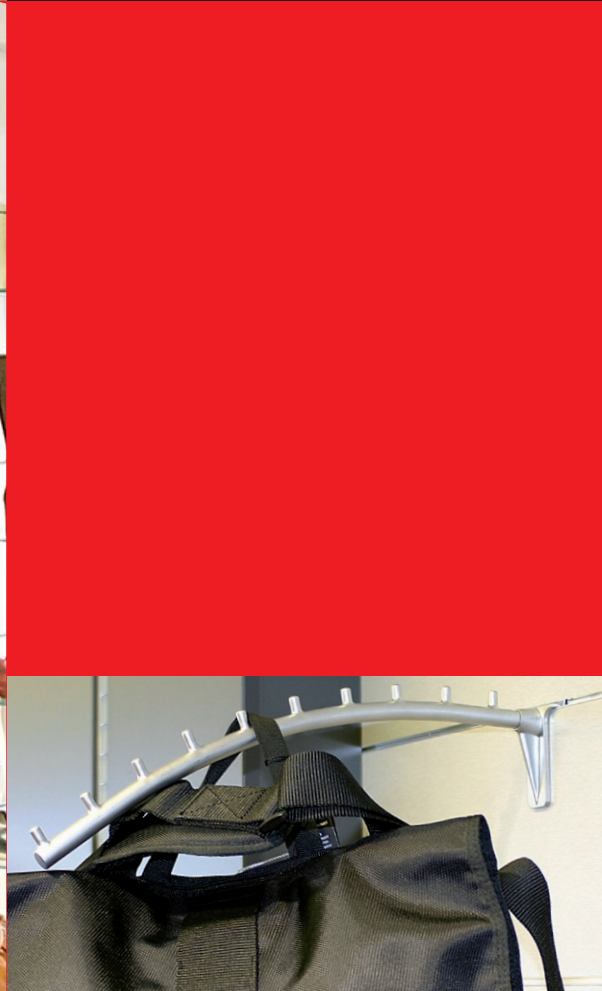

PANELS AND INSERTS.



MDF unfinished	Oak, laminated	Beech, laminated	Cherry, laminated	Maple, laminated
Walnut, laminated	White, laminated	Black, laminated	White, high gloss, laminated	Black, high gloss, laminated
Brushed aluminium, laminated	Grey, laminated	Other colours available. Please contact us for more information.		

ALL SLIM PANELS, INSERTS AND ACCESSORIES ARE ONLY BY ORDER, NOT ON STOCK.

	<p>PANELS "LANDSCAPE"</p> <ul style="list-style-type: none"> MDF Unfinished White Laminated Black Laminated Grey Laminated Brushed Aluminium Maple Laminated Oak Laminated Cherry Laminated Beech Laminated Walnut Laminated Cream Laminated White High Gloss Laminated Black High Gloss Laminated 	<ul style="list-style-type: none"> SSL 701 SSL 704 SSL 725 SSL 705 SSL 722 SSL 707 SSL 708 SSL 716 SSL 717 SSL 726 SSL 714 SSL 727 SSL 728
	<p>PANELS "PORTRAIT"</p> <ul style="list-style-type: none"> MDF Unfinished White Laminated Black Laminated Grey Laminated Brushed Aluminium Maple Laminated Oak Laminated Cherry Laminated Beech Laminated Walnut Laminated Cream Laminated White High Gloss Laminated Black High Gloss Laminated 	<ul style="list-style-type: none"> SSP 701 SSP 704 SSP 725 SSP 705 SSP 722 SSP 707 SSP 708 SSP 716 SSP 717 SSP 726 SSP 714 SSP 727 SSP 728
	<p>INSERT, ALUMINIUM</p> <ul style="list-style-type: none"> Insert, aluminium 2400mm 	<ul style="list-style-type: none"> AF 805

ALUMINIUM & PVC CONNECTORS.

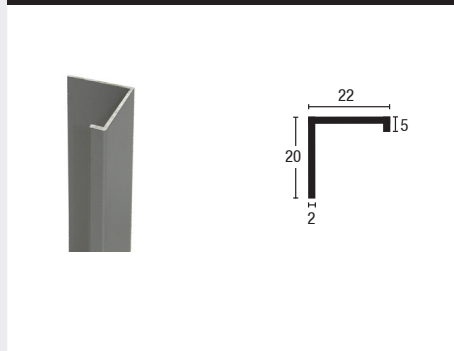

END CAP

MF 255

Aluminium, anodized 2500mm.

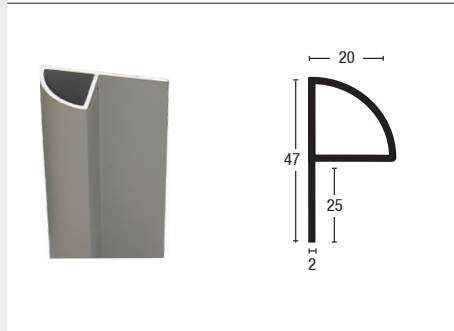

END CAP

MF 256

Aluminium, anodized 2500mm.

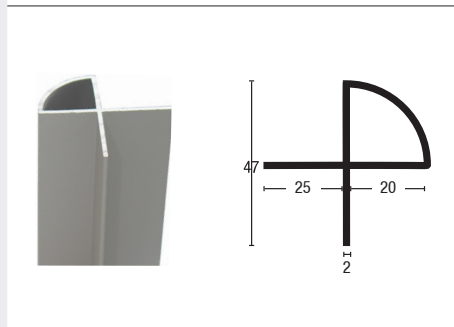

CORNER CONNECTOR

MF 257

Aluminium, anodized 2500mm.

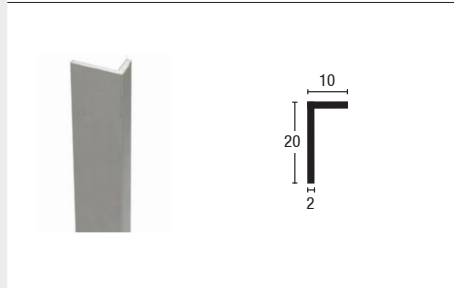

END CAP

MF 295

Aluminium, raw finish 2400mm.
 - " - white 2400mm.

MF 295W

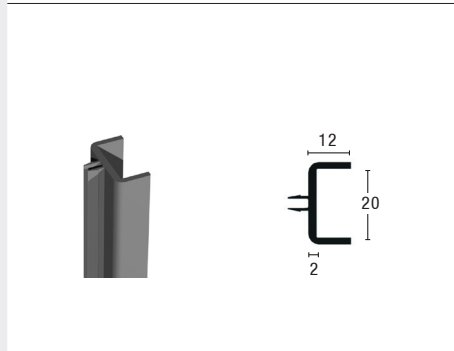
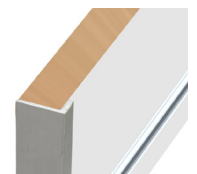



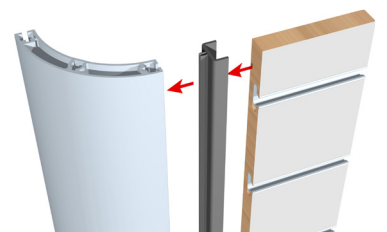

CONNECTING PROFILE

E 429

PVC plastic, grey 5000mm.
 For 20mm. panels. Cut to size.

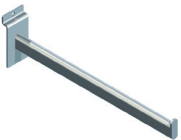

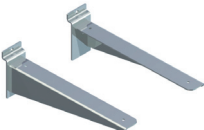

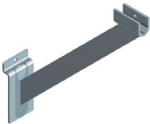

	10 BALL SLOPING ARM	
	270mm	SF 202
	STRAIGHT ARM WITH STOP	
	300mm	SF 204
	SINGLE DISPENSER ARM	
	Single dispenser arm – “ –	150mm 200mm SF 208 SF 209
	TIMBER SHELF BRACKET	
	Timber shelf bracket – “ – Ordered in pairs.	200mm 250mm SF 212 SF 213
	HANGING RAIL	
	Hanging rail	600x300mm SF 220
	HANGING RAIL SIDE SUPPORT	
	Side support for SF 220	SF 243

.ACCESSORIES.

	<p>STRAIGHT ARM WITH PIN</p> <p>100mm 230mm 350mm</p>	<p>SF 704-1 SF 704-2 SF 704-3</p>
	<p>Z-ARM WITH PINS</p> <p>360x110mm</p>	<p>SF 705</p>
	<p>SLOPING ARM WITH 9 PINS</p> <p>350x170mm 350x170mm with strenghtened backplate</p>	<p>SF 706 SF 726</p>
	<p>SHELF BRACKET</p> <p>For 8mm wooden or glass shelves</p> <p>200mm version 1 300mm version 1 200mm version 2 300mm version 2</p>	<p>SF 707-1 SF 707-2 SF 708-1 SF 708-2</p>
	<p>SHELF BRACKET</p> <p>For 8mm wooden or glass shelves, with bearing for hanging tubes SF 722-1 and -2</p> <p>300mm version 1 300mm version 2</p>	<p>SF 709 SF 710</p>



	BRACKET FOR HANGING TUBES 300 mm	SF 711
	SHELF BRACKET For 8 mm wooden or glass shelves 200 x 240 mm	SF 713
	GLASS SHELF BRACKET For 8 mm glass shelves 50 mm	SF 714-1
	DOUBLE HOOK 100 mm 150 mm 200 mm 250 mm	SF 715-1 SF 715-2 SF 715-3 SF 715-4
	SINGLE HOOK 60 mm 100 mm 150 mm 200 mm 250 mm	SF 716-1 SF 716-2 SF 716-3 SF 716-4 SF 716-5
	STRAIGHT ARM 100 mm 230 mm 350 mm	SF 720-1 SF 720-2 SF 720-3

.ACCESSORIES.



BRACKET FOR HANGING TUBES

With bearing for hanging tubes SF 722-1 and -2,
straightened backplate

SF 721



LEAFLET HOLDER

40x160x220mm (DIN A5)
40x220x225mm (DIN A4)

SF 717-1
SF 717-2



SHELF

for shoes and dry goods

SF 718



DISPLAY

For gloves, scarfs, small goods, etc.
150x300x35mm
150x150x35mm

SF 741
SF 742







DISPLAY

30° slant
310x220x60mm, lip 100mm

SF 745



	HANGING TUBES For bracket SF 709, 710, 711, 721. Diameter 21mm. 620mm 1000mm	[REDACTED] SF 722-1 SF 722-2
	ANGLED BOOK HOLDER Slant 155x100x100mm, lip 15mm	[REDACTED] SF 746
	DISPLAY 255x305x150mm	[REDACTED] SF 758
	MULTI-PURPOSE DISPLAY 88x220x130mm, lip 80mm	[REDACTED] SF 759

EXQUISITE LOOK WITH SATIN CHROMED METALL AND HANDMADE PLASTIC ACCESSORIES.

WHEN APPLIED AND IF NOT OTHER SIZE SPECIFIED, THE DIAMETER OF THE ACCESSORIES IS 14MM AND THE PLASTIC IS 4MM THICK.



TECHNICAL INFORMATION.

TESTED LOAD CAPACITY*!

PANEL WITH ALUMINIUM INSERT: 25 Kg

* Load capacity examined with evenly distributed weight on shelf 100 x 30 cm with two rackets and professional mounting. High safety factor withdrawn. Tested by LGA testing institute, march 2010.

THE IMPORTANCE OF METICULOUS PREPARATIONS

Find and mark the highest point on the wall of which the panel is to be mounted.

Draw a perfectly straight line with a water level along the whole width of the wall. Preferably 1200mm from the floor.

If the highest point deviates from the lowest with 20mm or more, you have to use wooden blocks to get the level right. When the panel is mounted it should always be fixed to the wall in the groove.

Use a 5mm drill and always a counter sunk screw. To mount a whole panel, you should use approx. 20 screws, divided into four vertical- and five horizontal rows. The screws at the edges should be set 20mm from the edge.

Always start mounting a set of panels from the corner of the room.

When cutting a Slotwall board we recommend using a wall-mounted saw or similar for perpendicular cuts. The saw blade should have a trapeze cut, hardened steel edge. Especially if the panel has a set of aluminium inserts mounted.

If you need to cut the board in two, a carpenter's saw or a buzz saw is alright. Remember to cut the board from the backside.

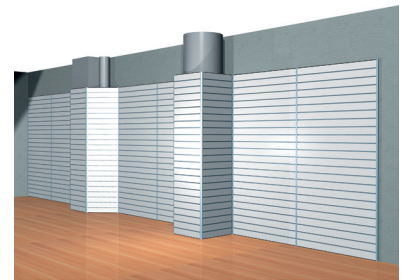
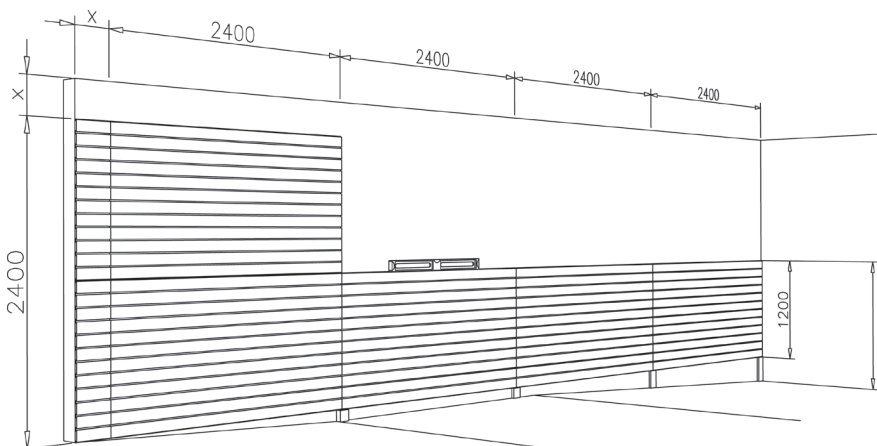

The connectors on page 8 add a nice finishing touch to the ends and corners of the panels.

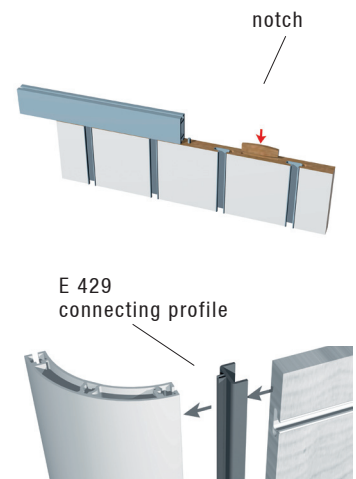

If you wish to integrate the panel with an aluminium beam from OCTANORM® there are three solutions at hand. To notch, tap or using the E429 connecting profile.

GENERAL INSTRUCTIONS FOR SLOTWALL PANELS

Height: 1200mm. Length: 2400mm. Distance between slots: 100mm. Thickness: 18mm.

If there is a laminate or powder coat applied to the surface it will increase the thickness.

The following measured distances in slots can be provided: 50mm, 75mm, 100mm (standard), 200mm, 300mm and 750mm. If need, other distances can be offered.

Panels can be supplied with a thickness of 25mm for a two sided exposure.

Individually spaced grooves can also be arranged.

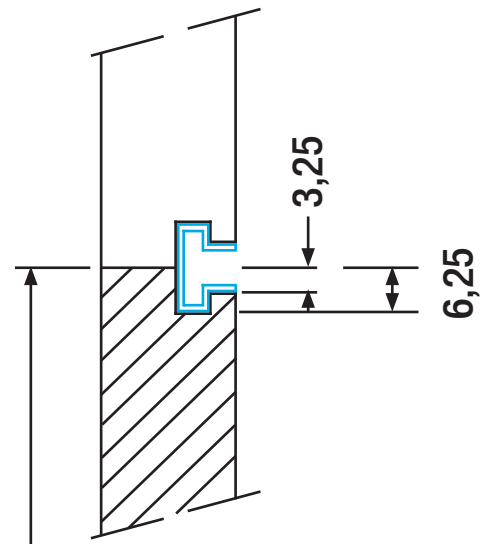
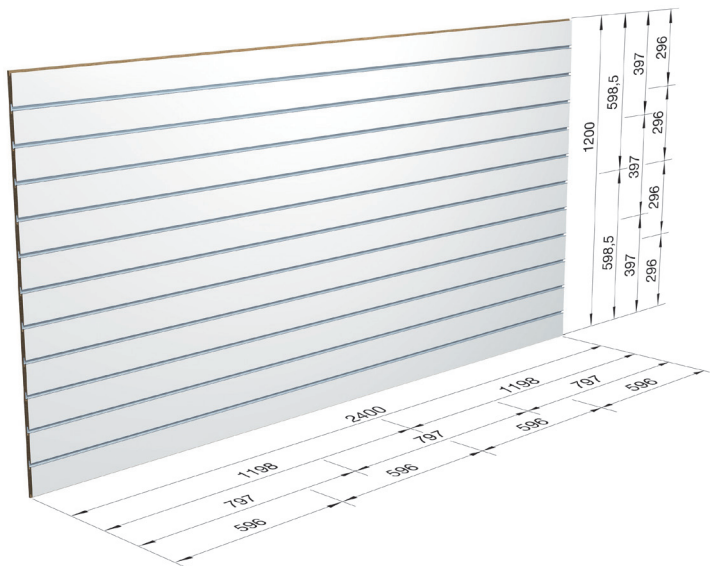

MANAGING THE PANELS:

Avoid dragging/pulling the panels when on top of each other.

Be extra careful with the ends.

STORING THE PANELS:

The panels must be stored and transported lying flat upon a pallet. They should always be stored in a dry environment.

Never lean a panel against other object or wall, as the panel will curve and can break.

FUNCTION
& FORM - THAT'S
OCTANORM.

- exhibition systems
- shopfitting systems
- presentation systems
- cleanroom systems
- software and service

THE
WORLD
OF
SYSTEMS

www.octanorm.se

OCTANORM [®]
NORDIC

octanorm nordic_spacewall slim_2012-03